

PROJECT
SPECIFICATIONS

FOR

**PHILLIPS RANCH PARK –
DOG PARK**

Prepared by



COMMUNITY WORKS DESIGN GROUP
Landscape Architecture - Park Planning
4649 Brockton Avenue
Riverside, California 92506

For

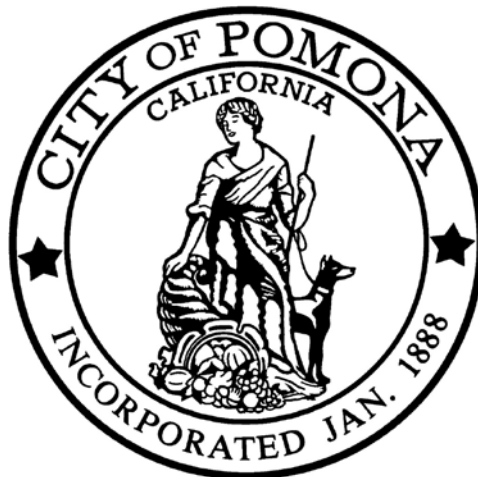

City of Pomona
PUBLIC WORKS DEPARTMENT
505 S Garey Avenue
Pomona, CA 91766

PHILLIPS RANCH PARK – DOG PARK
CITY OF POMONA
TECHNICAL SPECIFICATIONS

TABLE OF CONTENTS:

DIVISION 1	GENERAL REQUIREMENTS
01000	MOBILIZATION
01300	SUBMITTALS
DIVISION 2	SITE CONSTRUCTION
02110	SITE CLEAR & GRUB
02210	SITE GRADING
02221	DECOMPOSED GRANITE
02441	IRRIGATION
02444	CHAIN LINK FENCING
02445	TEMPORARY CHAIN LINK FENCING
02470	SITE FURNISHINGS
02480	PLANTING
DIVISION 3	CONCRETE
03010	CONCRETE
03310	FOOTINGS & FOUNDATIONS
03380	CONCRETE CURING

SECTION 01000 - MOBILIZATION

PART 1 – GENERAL

1.01 RELATED DOCUMENTS:

The provisions of *The “Greenbook” Standard Specifications for Public Works Construction* shall apply except as modified herein.

1.02 SCOPE OF WORK:

The Work of this Section shall consist of furnishing all labor, materials, equipment, appliances and services necessary for the execution and completion of all Mobilization Work as shown on the Plans and as described in the Specifications including, but not necessarily limited to, the following:

- Preparatory operations including, but not limited to those efforts necessary for the movement of personnel, equipment, supplies, and incidentals to the Work site;
- All other operations which must be performed or costs incurred prior to beginning Work on the site;
- Provision and installation of Construction Fence per Technical Specification Section **02445 Temporary Chainlink Fence**;
- Provision of temporary utilities;
- Secure all required permits;
- Obtain temporary construction water & electrical service
- Submittals per Special Provisions Section **2-5.3.3 Shop Drawings and Submittals** and Technical Specifications Section **01300 Submittals**.

1.03 SUBMITTALS:

As a part of mobilization, all submittals as specified in various individual Sections of the Specifications shall be submitted for approval by the City in the format specified in Technical Specifications Section **01300 Submittals** and within the time-frames specified in Special Provisions Section **2-5.3.3 Shop Drawings and Submittals**. Submittals shall include all Materials Lists, Catalog Cuts, Shop Drawings, material and color samples, and Construction Schedule all as specified.

PART 2 - MATERIALS

2.01 TEMPORARY UTILITIES:

The permanent potable domestic water meter is already in place and available for use on the Project. Contractor shall furnish temporary water (if need exceeds safe rate of flow through existing water meter), and power complete with connecting piping, wiring, lamps, meters and similar equipment as required for the Work. Install, maintain, and remove temporary lines upon completion of the Work. All expenses in connection with temporary services and facilities shall be paid for by Contractor.

PART 3 – EXECUTION

3.01 GENERAL:

- A. Payment: The price of this item is included in the various items of work and shall include but not limited to all activities, equipment, supplies, and incidentals to the project site; for the establishment of all offices,

buildings and other facilities necessary for the work on this project; and for all other work and operations of the Contractor's forces which must be performed or cost incurred, prior to the beginning of work on the various contract items on the project site under the Contract. No separate payment will be made for mobilization, and no further compensation will be allowed therefore.

3.02 CLEAN-UP:

Contractor shall provide trash receptacles for collecting debris, shall remove debris from the job site at regular intervals not less than weekly and shall dispose of same in a legal manner.

END OF SECTION

SECTION 01300 - SUBMITTALS

PART 1 - GENERAL

1.01 RELATED DOCUMENTS:

The provisions of the *The "Greenbook" Standard Specifications for Public Works Construction* shall apply except as modified herein.

1.02 SCOPE OF WORK:

The Work of this Section shall consist of furnishing all labor, materials, equipment, appliances and services necessary for the execution and completion of all Submittals Work as shown on the Plans and as described in the Specifications including, but not necessarily limited to, the following:

- Preparation of Submittals Schedule;
- Submittals Planning;
- Submittals Preparation, Distribution and Transmittal, to include all of the following:
 - Product Data (Catalog Cuts);
 - Materials Lists;
 - Samples;
 - Record Drawings;
 - Turn-over Items;
- Submittals Schedule updating and distribution;

1.03 RELATED WORK SPECIFIED ELSEWHERE:

Shop Drawings and Submittals
Construction Schedule

Special Provisions Section 2-5.3.3
Special Provisions Section 6-1.1

1.04 SUBMITTAL PLANNING:

- A. Processing Lead Time: Allow sufficient review time so that installation will not be delayed as a result of the time required to process submittals, including time for resubmittals.
1. Allow two (2) weeks for initial review. Allow additional time if processing must be delayed to permit coordination with subsequent submittals. The City representative will promptly advise Contractor when a submittal being processed must be delayed for coordination.
 2. If a resubmittal is necessary due to corrections or revisions, process the resubmittal in the same manner as the initial submittal.
 3. Allow two (2) weeks for processing each resubmittal.
 4. No extension of Contract Time will be authorized because of failure to transmit submittals to the City representative sufficiently in advance of the Work to provide the two week processing time specified.

B. Coordination and Completeness:

1. Contractor shall coordinate preparation and processing of submittals with the performance of the related Work. Transmit each submittal allowing sufficient lead time to obtain appropriate reviews and approvals and to avoid delays in the related Work.
2. Coordinate the submittal date for each submittal with the lead time needed for fabrication, purchasing, testing, delivery, review of other related submittals, and related Work that require sequential processing/completion.
3. Coordinate the transmittal dates for each different type of submittal so processing will not be delayed. Ensure concurrent transmittal of submittals for related portions of the Work that need concurrent review to allow the PA to verify that a coordinated work effort is being provided. City and PA each reserves the right to withhold action on a submittal requiring coordination with other submittals until related submittals are received.
4. Contractor is responsible to verify completeness of all submittals. Incomplete submittals will be rejected.

1.05 SUBMITTALS SCHEDULE:

- A. Concurrently with the development of Contractor's Construction Schedule (per Special Provisions Section 6-1.1 CONSTRUCTION SCHEDULE), prepare a complete "Submittals Schedule" for all submittals. Submit the Submittals Schedule together with the Construction Schedule at the Pre-Construction meeting.
 1. Coordinate the Submittals Schedule with all subcontractors, with the schedule of values, with the Materials Lists and with the Construction Schedule.
 2. Itemize items on the Submittals Schedule in the chronological sequence planned for submission; include all submittals required by the Contract Documents. Provide the following information:
 - a) Scheduled date for the initial submittal for each item.
 - b) Related Specification Section number.
 - c) Submittal category (i.e. Product Data, Samples, Record Documents, Shop Drawing, etc.).
 - d) Name of subcontractor or supplier as applicable.
 - e) Description of the portion of the Work covered by the submittal.
 - f) Record successive date(s) of any resubmittal(s).
 - g) Record date of City approval of each submittal.
- B. Submittals Schedule Updating: Update the Submittals Schedule after each meeting or activity where revisions have been recognized or made.
- C. Distribution: Following receipt of review comments to the initial Submittals Schedule, on a monthly basis thereafter issue updated copies of the Submittals Schedule. Distribute copies to the Landscape Architect, the City representative, all subcontractors, and all other parties required to comply with scheduled submittal dates. Keep an up to date copy of the Submittals Schedule posted in the Construction Office. Parties may be deleted from the distribution upon completion of all portion(s) of the Work assigned to such parties and such parties are no longer involved in construction activities.

1.06 SUBMITTALS PREPARATION AND TRANSMITTAL:

- A. Preparation: Place a permanent label or title block on each submittal for identification. Indicate the name of the entity that prepared each submittal on the label or title block.
1. Provide a space approximately 4" x 5" on the label or beside the title block on Shop Drawings to record Contractor's review and approval markings and the action taken.
 2. Include the following information on the label for processing and recording action taken.
 - a) Project name.
 - b) Date.
 - c) Name and address of PA.
 - d) Name and address of Contractor.
 - e) Name and address of subcontractor (as applicable).
 - f) Name and address of supplier.
 - g) Name of manufacturer.
 - h) Number and title of related Specification Section.
 - i) Drawing number and detail references, as appropriate.
- B. Transmittal: Forward one electronic copy of each submittal appropriately for transmittal and handling. Transmit each submittal from Contractor to the City representative using a transmittal form. Submittals received from sources other than Contractor may be returned without action. If a submittal is rejected, submit one electronic copy of the resubmittal.
1. When transmitting submittals, record relevant information and requests for data on the transmittal form. Include a Contractor's certification that information submitted complies with the Contract Document requirements as a part of each submittal. If the submittal is not in full accordance with the Contract Documents, record specific deviations from the Contract Document requirements, including minor variations and limitations, either on the transmittal form or on a separate attached sheet that is referenced on the form.
 2. Transmittal Form: Use AIA Document G 810, or City approved equal.

1.07 SUBMITTALS PROCESSING AND DISTRIBUTION:

- A. Processing: Upon receipt of the submittals, the City representative will retain one copy and forward an electronic copy to the PA who will retain one, and will return an electronic copy marked with action taken. Electronic copies will be forwarded to the PA who will return an electronic copy with action taken.
1. Except for submittals for record information or similar purposes, where action and return is required or requested the City or Landscape Architect will review each submittal, mark to indicate action taken, and return promptly.
 2. Verification of the submittals compliance with characteristics specified in the Contract Documents is Contractor's responsibility.
 3. Action Stamp: The City or Landscape Architect will stamp each submittal with a uniform, self-explanatory action stamp. The stamp will be appropriately marked, as follows, to indicate the action taken:

- a) "No Exception Taken": When submittals are marked "No Exception Taken," that part of the Work covered by the submittal may proceed.
- b) "Make Corrections Noted": When submittals are marked "Make Corrections Noted," that part of the Work covered by the submittal may proceed provided it complies with the notations and corrections marked on the submittal as well as the requirements of the Contract Documents.
- c) Returned for Resubmittal: Submittals may be returned for resubmittal for various reasons. When a submittal is marked either "Submit Specified Item," "Rejected," or "Revise and Resubmit," Contractor shall not proceed with any part of the Work covered by the submittal, including purchasing, fabrication, delivery, or any other associated activity. Instead, the submittal shall either be revised to comply with the Contract Documents and resubmitted, or a new submittal shall be prepared in accordance with the notations and submitted; resubmit without delay.
- d) Other Action: Where a submittal is primarily for information or record purposes, special processing or other activity, the submittal will be returned, marked "Action Not Required".
- e) Contractor shall repeat the submittal process as specified above for all submittals as necessary to obtain an action mark that will allow the Work to proceed.

B. Distribution: Upon receipt of marked copies of the submittals from the Landscape Architect, the City representative will forward four hard copies or one electronic copy of the marked submittal to the Prime Contractor for further distribution to the Subcontractor(s) and/or Supplier(s).

- 1. Do not proceed with the Work until an appropriately marked copy of the applicable submittal has been received from the City and is in the installer's possession.
- 2. Do not permit use of unmarked copies of submittals in connection with construction.
- 3. Contractor shall not permit submittals marked "Rejected," "Submit Specified Item", or "Revise and Resubmit" to be used at the Project site, or elsewhere where Work is in progress.

1.08 PRODUCT DATA ("CATALOG CUTS"):

A. Submittal: Assemble Product Data submittals into a single submittal package for each construction trade or system (e.g. Plumbing, Electrical Lighting, Concrete, HVAC, etc.). Submittals shall consist of one electronic copy. Product Data submittals shall include all available printed information such as manufacturer's installation instructions, catalog cuts, standard color charts, roughing-in diagrams and templates, standard wiring diagrams and performance curves. Where Product Data must be specially prepared because standard printed data is not suitable for use, submit as "Shop Drawings."

- 1. Mark the copy to show applicable choices and options. Where printed Product Data includes information on several products, some of which are not required, mark copies to delete inapplicable information. Product Data submittals, as a minimum, shall include the following information:
 - a) Manufacturer's printed recommendations.
 - b) Compliance with recognized trade association standards.
 - c) Compliance with recognized testing agency standards.

- d) Application of testing agency labels and seals.
 - e) Notation of dimensions verified by field measurement.
 - f) Notation of coordination requirements.
2. Do not submit Product Data until Contractor has confirmed the product's compliance with requirements of the Contract Documents.

1.09 SAMPLES:

- A. General: Submit full-size, fully fabricated Samples cured and finished as specified, in the quantity specified in the respective Technical Specification section, and physically identical with the material or product proposed. Where quantities are not specified in the Technical Specification, submit a minimum of three samples, one will be returned marked with the action taken. Samples include partial sections of manufactured or fabricated components, cuts or containers of materials, color range sets, and swatches showing color, texture and pattern.
- 1. Mount, display, or package Samples in the manner specified to facilitate review of qualities indicated. Prepare Sample Submittals to match the PA's Sample when available. Include the following:
 - a) Generic description of the Sample.
 - b) Sample source.
 - c) Product name or name of manufacturer.
 - d) Certification of compliance with the specified standards.
 - e) Availability and delivery time.
 - 2. Submit Samples for review of kind, color, pattern, and texture, for a final check of these characteristics with other elements, and for a comparison of these characteristics between the final submittal and the actual component as delivered and installed. Where variation in color, pattern, texture or other characteristics are inherent in the material or product represented, submit multiple units (not less than 3), that show approximate limits of the variations.
 - 3. Preliminary submittals: Where Samples are for selection of color, pattern, texture or similar characteristics from a range of standard choices, submit a full set of choices for the material or product. Preliminary submittals will be reviewed and returned with the PA's mark indicating selection and other action.
 - 4. Maintain appropriately marked sets of Samples, as returned by the City, at the Project site for quality comparisons throughout the course of construction.
- B. Distribution of Samples: If additional sets of samples are needed for distribution to subcontractors, manufacturers, fabricators, suppliers, installers, and others as required for performance of the Work, Contractor shall submit samples in sufficient quantities for such distribution. Do not distribute unmarked copies of sample to others involved in the Work.

1.10 MATERIALS LISTS:

- A. Submittal Requirements: Submitting a catalog number and manufacturer's name as a materials list stating that the items will be furnished to meet the Specifications will not be acceptable. Contractor shall submit a complete materials list for approval by the City representative prior to performing any Work. Catalog data and full descriptive literature must be submitted whenever the use of items

different than those specified is requested. Notarized certificate must be submitted by plastic pipe and fitting manufacturer indicating that material complies with the Project Specifications, unless material has been previously approved and used on other projects by the DISCTRICT.

Material list shall be submitted in a format similar to the following:

<u>Item</u>	<u>Description</u>	<u>Manufacturer</u>	<u>Model No.</u>
1.	Pressure Supply Line	Lasco	Sch. 40
2.	Lawn Head	Rainbird	2400
etc.	etc.	etc.	etc.

1.11 "RECORD" PRINTS:

- A. Changes: Record accurately on one set of blue-line prints all changes in the Work constituting departures from the original Contract Plans. For example, changes in pressure and non-pressure irrigation line locations.
- B. Legibility and Approval: The changes and dimensions shall be recorded in a legible and workmanlike manner to the satisfaction of the City. Prior to final inspection of the Work, submit "record" prints to the City representative for approval.
- C. Reference Points: Dimension from two permanent points of reference (buildings, monuments, sidewalks, curbs, pavement, etc.). Data to be shown on "record" prints shall be recorded day-to-day as the project is being installed.
- C. As-built Items: Show locations and depths of the following types of underground items:
 - 1. Point(s) of connection for irrigation, domestic water, gas, sewer, electric and similar underground utilities.
 - 2. Routing of underground conduits, irrigation pressure lines and utility lines (dimension maximum 100 feet on center along routing).
 - 3. All types of valves in various piping systems, including gate valves, quick coupler and remote control valves.
 - 4. Routing of irrigation control wires.
 - 5. Related equipment (as may be directed).
- D. Maintain record prints on site at all times.

PART 2 - MATERIALS (See 'MATERIALS' part of each specification section.)

PART 3 - EXECUTION (See 'EXECUTION' part of each specification section.)

END OF SECTION

SECTION 02110 - SITE CLEAR AND GRUB

PART 1 - GENERAL

1.01 RELATED DOCUMENTS:

The provisions of *The "Greenbook" Standard Specifications for Public Works Construction* shall apply except as modified herein.

1.02 SCOPE OF WORK:

Furnish all material, equipment and labor necessary to perform all clearing and grubbing work complete, including but not limited to the following:

Protection of trees indicated on drawings to remain.

Clearing and grubbing of all vegetation from site work areas.

Removal and disposal of all deleterious materials.

Furnishing, developing, applying and providing dust control watering equipment as required for the project.

1.03 RELATED WORK SPECIFIED ELSEWHERE:

Planting	Section 02480
Irrigation	Section 02441

1.04 RESPONSIBILITY AND COORDINATION:

Contractor shall secure and maintain all required permits and licenses, and pay all fees necessary to legally complete the work of this section.

Contractor shall notify utility companies for all utilities to be cut off, modified or relocated, and shall maintain and protect all active utilities.

Contractor shall coordinate all work with the City in an effort to avoid any conflicts with the parks maintenance schedules.

1.05 PROTECTION AND SAFETY:

Contractor shall provide signs in necessary places to exclude persons, except those connected with the work, from entering the working area. Contractor is responsible for preventing unauthorized persons from entering working area.

Protect the project site and adjacent properties from dirty water, mud and water accumulated due to Contractor's operations, rainfall runoff or water that enters the project site from any other sources.

PART 2 - MATERIALS - Not applicable.

PART 3 - EXECUTION

3.01 GENERAL REMOVAL WORK:

Removal work shall be carefully done to avoid damage to all existing facilities to remain.

3.02 SITE CLEARANCE AND DISPOSAL:

Clear the sites to be improved of grass, shrubs, weed growth, rubbish and debris, etc., that are to be removed for construction of the improvements shown on the construction plans. Roots three inches in diameter and larger, rocks and broken masonry larger than 1 inch in the greatest dimension, shall be removed to a minimum depth of 12" below finished grade.

All deleterious materials shall be disposed of off the site in a legal manner by the Contractor, who shall make all necessary arrangements and pay all related costs.

Miscellaneous existing underground facilities, drainage devices, secondary water lines, cables, abandoned oil and water lines, leaching fields, irrigation pipes, wiring, etc, located 12 inches or more below proposed finish grade may be abandoned in place or removed as necessary for proper completion of the work. All miscellaneous active lines that are uncovered during the grading operations shall be protected.

3.03 UTILITIES:

Inactive or abandoned utilities shall be disconnected, removed, and plugged or capped subject to the local governing ordinances.

Should the Contractor encounter any existing underground utilities not shown on the drawings, he shall at once notify the Landscape Architect who will determine further procedure.

3.04 DEBRIS BURNING:

Burning of debris will not be permitted.

3.05 DUST CONTROL:

Dust shall be kept to a minimum during site clearing operations by means of wetting the site or other approved method. Wash down all existing sidewalks and roadways on and off the site after all operations are complete.

END OF SECTION

SECTION 02210 - SITE GRADING

PART 1 - GENERAL

1.01 RELATED DOCUMENTS:

The provisions of *The "Greenbook" Standard Specifications for Public Works Construction* shall apply except as modified herein.

1.02 SCOPE OF WORK:

Furnish all material, equipment and labor as necessary to perform all earthwork complete, including, but not limited to, the following:

SWPPP and WQMP

Rough grading as shown on the plans, including cut, fill, backfill and backfill compaction

Subgrade preparation trail

Finish grading of the site

Excavation and backfill for all footings

Soil compaction as required

Soil testing as required

Protective measures

Dust and noise abatement

Borrow excavation as directed

1.03 RELATED WORK SPECIFIED ELSEWHERE:

Excavation and backfill for any irrigation

Section 02441

Fine finish grading in landscaped areas (Planting)

Section 02480

1.04 QUALITY ASSURANCE:

A. All work shall comply with the requirements of the following:

- (1) The Grading Code of the City of Pomona
- (2) California Building Code (CBC) 2013 Edition

B. Tests and Inspections:

- (1) All work in this section shall be subject to the observation and testing as required by the Soils Engineer selected by the City representative. The Soils Engineer shall submit a compaction report to the City representative, certifying the Contractor's compliance with the plans, specifications, soils reports and City grading ordinance in placing all fills and backfills. The Soils Engineer shall conduct all specified tests to insure compliance. Soils Engineer shall also test, identify and make recommendations on borrow site fill materials as specified in this section.

- (2) Number and location of soils tests to be at the discretion of the Soils Engineer to assure uniformity and compliance with the City grading ordinance, but at least one

test per two vertical feet of fill, but not less than one test per 500 cubic yards, all as approved by the City representative.

- (3) The costs of services of the Soils Engineer, specified field density and maximum density tests, compaction reports and certificates of compliance, shall be borne by the Contractor. Additional tests and re-compactions made necessary by inadequate compaction, inadequate materials provided by contractor, and inaccurate excavations shall be paid for by the Contractor at no additional cost to the City.

1.05 GRADING OPERATIONS:

It is the intent of the drawings that the grading shall be an export operation an estimated amount of 45 cubic yards of export material. No import is contemplated. If during grading operations an excess or deficiency of earth becomes apparent, the grading shall be completed with site material conforming as nearly as possible to the finish grades shown and insuring positive drainage without additional cost to the City.

1.06 WATER:

Contractor shall make arrangements with the Metropolitan Water District to obtain construction water.

1.07 JOB CONDITIONS:

A. Protection of Existing Items:

- (1) The Contractor shall furnish, place and maintain all shoring and bracing as may be required for protection of existing structures and utility services during execution of the work. The adequacy of and responsibility for this shall be the Contractor's completely.
- (2) All bench marks, monuments and other reference points shall remain undisturbed unless specifically directed otherwise by the City representative.

B. Protection of Public:

The Contractor shall provide such barricades, temporary fences, gates, lights, warning signs, guards, and other measures as may be necessary to assure safety and to deter trespassers. These provisions shall be maintained during the entire duration of the work. These temporary facilities shall be constructed, painted, and maintained in strict conformance with the requirements of applicable codes and other governing authorities.

C. Coordination with Others:

- (1) Contractor shall give written notice to the Owner, utility agencies, and other legal authorities prior to starting work.
- (2) Contractor shall coordinate his operations with other trades, utility firms, and other affected public departments to assure continuity for both access and service of all utility, service distribution lines, in conformance with applicable requirements of

these organizations. No services to any property shall be impeded.

D. Abandoned and Unknown Utilities:

- (1) Abandoned lines, meters and boxes, obstructions or piping, shall be removed, plugged, or capped in accordance with the requirements and approval of the agencies affected, or as directed by the City representative. Coordinate all such work with applicable mechanical or electrical trade having responsibility. Remove all abandoned utility lines, pipes, or conduits, to a point outside new construction lines.
- (2) Where unmarked utility lines or other underground obstructions or piping are uncovered within the work area, notify the City representative, or the agencies or service utility companies having jurisdiction and take necessary measures to prevent interruption of service. Should such lines or services be damaged, broken, or interrupted through the Contractor's own negligence, those services shall be repaired immediately and restored by him at his own expense.

PART 2 - MATERIALS

2.01 IMPORT: (If Applicable)

- A. All import soil used for fill in landscape areas shall be Class `A' topsoil per latest edition of *The "Greenbook" Standard Specifications for Public Works Construction*, Section 212.
- B. All import soil used for structural fill shall be non-expansive, predominantly granular material free from organic contaminants, and capable of attaining the required compacted densities.
- C. All import soil must be approved at the borrow site by the Soils Engineer.

2.02 FILL MATERIAL:

- A. All fill material must be approved by the Soils Engineer.
- B. On-site excavated materials may be used as approved by the Soils Engineer. Landscape fill shall be Class `A' topsoil.
- C. Rocks larger than 3 inches in diameter shall be removed from all fills to be compacted.

2.03 GRANULAR BEDDING MATERIAL:

Where called for on the plans, granular bedding material shall be crushed stone or pea gravel conforming to the following gradient:

<u>Sieve Size</u>	<u>Passing</u>
3/4"	100
1/2"	95
4"	5

2.04 AGGREGATE BASE:

Crushed aggregate base shall consist entirely of crushed rock and rock dust conforming to the requirements of Section 200-2.2 of *The "Greenbook" Standard Specifications for Public Works Construction* and the Soils Investigation Report, maximum size aggregate shall be 3/4 inch.

PART 3 - EXECUTION

3.01 GENERAL:

A. All demolition and clearing and grubbing of objectionable materials must be completed to the satisfaction of the Soils Engineer before starting earthwork grading and excavation.

B. Survey:

Contractor shall provide all survey services necessary for horizontal and vertical control points, layouts, lines and levels, staking of work.

Any corrections to the grading work required to obtain proper drainage and to bring it into conformance with the intent of the plans and specifications and City codes shall be performed by Contractor at no additional cost to the City.

C. Contractor shall check all existing grades prior to initiating grading work as necessary to verify that the project can be graded as proposed. Any discrepancies found should immediately be brought to the attention of the City representative in writing.

3.02 ROUGH GRADING:

A. Rough grading of the site shall be in accordance with indicated contours, elevations, and limit lines shown on the plans and shall be sufficient to allow for the depths of slabs, paving, sub-base, topsoil, and compacted fills. Tolerance for rough grading is 1/10th of a foot. In all areas, appearance and positive drainage will be governing factors in acceptability of grades.

B. Graded material shall not be left in loose layers, but shall be stockpiled for use as compacted fill or compacted in thin layers as grading takes place in accordance with the requirements for compacted fill.

C. Scarification to a minimum depth of six (6) inches or to a depth permitting twelve (12) inches of controlled compacted fill shall be performed on all areas indicated to receive paving.

D. The Soils Engineer shall inspect all scarified surfaces prior to placement of compacted fill.

3.03 CONTROLLED FILL:

A. Fill material shall be spread in uniform lifts of six (6) to eight (8) inches of uncompacted thickness.

B. Prior to starting compaction, the fill material shall be brought to optimum moisture content by spraying with water if too dry, and aeration if too wet.

- C. Thoroughly mix each lift to assure uniform distribution of water content.
- D. Bring fills to suitable elevations above required grades to provide for effects of shrinkage and settlement.
- E. For all areas designated to receive slabs and pavement and within a perimeter five (5) feet outside these areas, each lift shall be compacted to a minimum of 90% of maximum density as determined by ASTM D1557-70.
- F. Where fill is required in planting areas each lift shall be compacted to a minimum of 85% maximum density.
- G. Perform all compaction by suitable mechanical equipment and methods approved by the Soils Engineer.
- H. Inspection and field tests shall be carried on during grading by the Soils Engineer to assist the Contractor in obtaining the required degree of compaction and the proper moisture content. Where compaction of less than 90% is indicated, additional compactive effort shall be made with adjustment of the moisture content as necessary until a minimum of 90% compaction is obtained.
- I. The material in any soft or spongy spots shall be removed to such depth as directed by the Soils Engineer and replaced with suitable material, properly compacted.
- J. Sub-grades to receive slabs and pavements shall be finished to a tolerance of plus or minus one-half (1/2) inch.

3.04 FINE GRADING:

Fine grading as specified in this section is distinguished from finish grading specified under Section 02480 Planting.

Finish grades shall slope to drain without water pockets or irregularities and shall conform to the intent of all plans and specifications after thorough settlement and compaction of the soil. Fine grading shall allow for soil preparation work as specified under section 02480 Planting, such that finish grades shall meet the elevations & grades indicated on the plans. Finish grades shall meet all existing or established controls of sidewalks and curbs, and shall be of uniform slope and grade between points of fixed elevations or elevation controls and from such points to established grades. Tolerance for finish grading is 1/4 inch, plus or minus.

Any corrections to the grading work required to obtain proper drainage and to bring it into conformance with the intent of the plans and specifications and City codes shall be performed by Contractor at no additional cost to the City.

3.05 EXCAVATION:

The Contractor shall make all necessary excavation for footings and slabs and to any additional excavation necessary to provide ample room for installation of concrete forms where required.

Footings may be poured against undisturbed soil if Soils Engineer approves.

Bottom of excavations shall be level, free from loose material and brought to the indicated or required grades in undisturbed earth. All excavations shall be kept free from standing water. The Contractor shall do all pumping or draining that may be necessary in carrying on the work. Should excavations for footings, through error, be excavated to a greater depth of size than indicated or required, such additional depth or size shall be filled with concrete, at the Contractor's expense.

3.06 BACKFILLING:

Select site material shall be used for backfill of trenches and shall be free from large stones and clods. Material shall be as approved by the Soils Engineer.

Backfill shall be deposited in layers of maximum six inch thickness.

Layers of backfill shall be moistened with water, the amount to be rigidly controlled to insure optimum moisture conditions for the type of fill material used. Excess water causing saturated earth beneath footings, walks, and curbs will not be permitted.

Backfill shall be compacted by suitable means to a minimum 90%.

All trenches shall be backfilled in accordance with this section, and may be tested at the discretion of the Engineer.

3.07 DUST AND NOISE ABATEMENT:

During the entire period of construction, site areas shall be kept sprinkled as necessary to reduce dust in the air and annoyance to surrounding properties. Adhere to the requirements of City ordinances for dust and noise control.

END OF SECTION

SECTION 02220 - INFIELD PREPARATION

PART 1 - GENERAL

1.01 WORK INCLUDED:

- A. Subgrade preparation
- B. Furnishing and installing infield mix material.

1.02 RELATED WORK SPECIFIED ELSEWHERE:

- A. Rough Grading

1.03 APPROVALS:

- A. Submit 5 pound sample of infield mix material for approval prior to ordering delivery. Attach supplier's certification of testing.
- B. Subgrade shall be approved prior to placing infield.

PART 2 - MATERIALS

2.01 EXISTING INFIELD MIX TO BE RE-USED

- A. Per Demolition and Construction plan sheets, the existing infield mix shall be stockpiled in a manner where it is harvested without the contamination of topsoil nor debris, and stored on-site so that it can be reused as the substrate for the new infield layout. The new infield topping (see 2.02 below) shall supplement the stockpiled and reused material and shall be used at the upper 1.5" of the infield surface.

2.02 INFIELD TOPPING:

- A. Infield topping shall have a gradation of a minimum of 98% of particles passing through the 2.00 mm sieve with the highest portion of sand particles in the medium to very fine range. Silt and clay distribution

<u>% Passing</u> <u>Min. - Max.</u>	<u>Sieve Size</u>
95 - 100	9.5 mm
65 - 95	500 micron
30 - 45	53 micron

Minimum 0.3% extractable calcium based on dry weight, utilizing 10% sodium acetate extracting solution

Suitable material is available from:

Gail Materials - "Pro Gold Premium Mound & Homeplate Mix" - (951)279-1095.

PART 3 - INSTALLATION

3.01 SUBGRADE PREPARATION:

- A. Rough grade to 3 inch depth below finish grade. Scarify to 6 inch depth and compact to 90% relative compaction. Subgrade shall be smooth and shall follow the drainage planes as shown on the drawings.

3.02 PRE-EMERGENT WEED CONTROL:

- A. Apply non-selective pre-emergent herbicide to subgrade, adhering strictly to manufacturer's printed instructions. Application shall be made by licensed Pest Control Applicator.

3.03 TOPPING COURSE:

- A. Scarify subgrade to one inch depth. Thoroughly moisten surface without flooding.
- B. Spread topping material in one 2 inch layer. Level the topping course to smooth plane surface. Thoroughly dampen and compact with minimum three-ton roller. Scarify, re-grade, and re-compact areas not conforming to finish grades as shown on the drawings.
- C. Areas adjacent to the pitcher's mound, home plate and all bases shall have infield material placed at not less than 4" thick, as measured after compaction, per plan.

3.04 WEED CONTROL:

- A. During the construction period, plant establishment and project maintenance periods, kill all vegetation upon discovery, using a non-selective contact herbicide in strict accordance with "label" instructions.

END OF SECTION

SECTION 02221 - DECOMPOSED GRANITE

PART 1 - GENERAL

1.01 WORK INCLUDED:

- A. Subgrade preparation
- B. Furnishing and installing decomposed granite and stabilizer

1.02 APPROVALS:

- A. Submit 10 pound sample of decomposed granite for approval prior to ordering delivery. Attach supplier's certification of testing.
- B. Subgrade shall be approved prior to placing.

PART 2 - MATERIALS

2.01 DECOMPOSED GRANITE:

- A. Decomposed granite shall be an imported blend of 1/4" minus crushed granite and clay, pre-mixed prior to delivery:

<u>% Passing</u>	<u>Screen Size</u>
100	3/8"
98	No. 4
77	No. 8
58	No. 16
45	No. 30
32	No. 50
22	No. 100
14.6	No. 200

2.02 SOIL STABILIZER:

Suitable material is 'Soil Secure' available from Southwest Boulder & Stone (877) 792-7625 or approved equal.

PART 3 - EXECUTION

3.01 SUBGRADE PREPARATION:

- A. Rough grade to 3 inch depth below finish grade. Subgrade shall be smooth and shall follow the drainage planes as shown on the drawings.

3.03 TOPPING COURSE:

- A. Scarify subgrade to one inch depth. Thoroughly moisten surface without flooding.

- B. Blend Soil Secure at the rate of 10 lbs. of Stabilizer per ton of decomposed granite. Blending may be done with cement mixer, pug mill, front end loader, or any similar piece of equipment. It is **essential** that the Stabilizer be mixed **thoroughly** and **uniformly** through the decomposed granite. Proper mixing is a must for a successful application.
- C. Spread topping material in one 2 inch layer. Level the topping course to smooth plane surface. Scarify, regrade, and re-compact areas not conforming to finish grades as shown on the drawings.
- D. Apply water until moisture penetrates to full depth of the Soil Secure. Water activates Stabilizer so it is **essential** that the **full depth** of the material receives water at this time.
- E. Upon thorough moisture penetration, compact the stabilized decomposed granite. Compaction can be done with small riding roller, power walk-behind roller, sod roller, vibrating plat tamp or similar.
- F. Allow finished surface enough time to dry completely. Set-up time varies, depending upon weather conditions.

END OF SECTION

SECTION 02441 - IRRIGATION

PART 1 - GENERAL

1.01 SCOPE OF WORK:

The work required is indicated on the drawings and includes, but is not limited to, lawn and shrub irrigation systems and remote control valves.

1.02 SUBMITTALS:

A. Materials List:

1. Complete material list shall be submitted prior to performing any work. Catalog data and full descriptive literature must be submitted whenever the use of the items different than those specified is requested. Notarized certificate must be submitted by plastic pipe and fitting manufacturer indicating that material complies with specifications, unless material has been previously approved.
2. Material list shall be submitted using the following format (double spaced between each item):

<u>Item</u>	<u>Description</u>	<u>Manufacturer</u>	<u>Model</u>
1.	Pressure Pipe	Lasco	Class 200
2.	Lawn Head	Rainbird	1804-SAM-PRS
Etc.	Etc.	Etc.	Etc.

B. Record Drawings:

1. Record accurately on one set of contract drawings all changes in the work constituting departures from the original contract drawings.
2. The changes and dimensions shall be recorded in a legible and workmanlike manner to the satisfaction of the City Representative. Prior to final inspection of work, submit record drawings to City Representative for approval.
3. Dimensions from two permanent points of reference (buildings, monuments, sidewalks, curbs, pavement, etc.). Data to be shown on record drawing shall be recorded day to day as the project is being installed. All lettering on drawings shall be minimum 1/8 inch in size.
4. Show locations and depths of the following items:
 - a. Point of connection.
 - b. Routing of sprinkler pressure lines (dimension maximum 100 feet along routing)
 - c. Gate valves.

- d. Sprinkler control valves.
 - e. Quick coupling valves.
 - f. Routing of control wires.
 - g. Related equipment (as may be directed).
5. Maintain record drawings on-site at all times. Upon completion of work, transfer all as-built information and dimensions to reproducible sepia prints.

1.03 INSPECTIONS:

A. Inspections Will Be Required For:

- 1. Coverage test.
- 3. Final inspection/start of maintenance. Final inspection shall be performed by the City in the presence of owner or his representative.
- 4. Final acceptance.

B. Inspection Requests:

Contractor shall notify the City Representative in advance for requesting all inspections as follows:

System layout - 36 hours (1-2 working days)
Coverage Tests - 36 hours (1-2 working days)
Final Inspection - 48 hours (2 working days)

When inspections have been conducted by other than the City Representative, the Contractor shall show evidence of when and by whom these inspections were made.

No inspection will commence without "record" prints. In the event the Contractor calls for an inspection without up to date "record" prints, without completing previously noted corrections, or without preparing the system for inspection, the inspection will be canceled and the Contractor back charged for the direct costs of all City personnel time and consultant time lost.

C. Closing In Uninspected Work:

Do not allow or cause any of the work of this section to be covered up or enclosed until it has been inspected, tested, and approved by the City Representative.

D. Coverage Test:

When the sprinkler system is completed, Contractor shall perform a coverage test in the presence of the City Representative and the Landscape Architect to determine if the water coverage for planting areas is complete and adequate. This test shall be accomplished before any planting.

1.04 TURNOVER ITEMS:

A. Controller Charts:

1. Record drawings must be approved by City Representative before charts are prepared.
2. Provide one controller chart for each automatic controller. Chart shall show the area covered by controller.
3. The chart is to be a reduced copy of the actual "record" drawing. In the event the controller sequence is not legible when the drawing is reduced, it shall be enlarged to a readable size.
4. Chart shall be a blackline print with a different color used to show the area of coverage for each station.
5. When completed and approved, the chart shall be hermetically sealed between two pieces of plastic, each piece being a minimum 20 mils in thickness.

B. Operation and Maintenance Manuals:

1. Two individually bound copies of operation and maintenance manuals shall be delivered to the City Representative 10 calendar days prior to final inspection. The manuals shall describe the material installed.
2. Each complete, bound manual shall include the following information:
 - a. Index sheet stating Contractor's address and telephone number, duration of guarantee period, list of equipment including names and addresses of local manufacturer representatives.
 - b. Complete operating and maintenance instructions for all equipment.
 - c. Spare parts lists and related manufacturer information for all equipment.

C. Equipment:

1. Supply as part of this contract the following items:
 - a. 4 additional sprinkler heads of each type and spray pattern shown.
 - b. Two (2) wrenches for disassembly and adjustment of each type of sprinkler

head involved.

- 2. The above equipment shall be turned over to the City Representative at the final inspection.

1.05 GUARANTEE:

- A. General: The entire sprinkler system, including all work done under this contract, shall be guaranteed against all defects and fault of material and workmanship for a period of one (1) year following the filing of the Notice of Completion. All materials used shall carry a manufacturer's guarantee of one (1) year.

Should any problem with the irrigation system be discovered within the guarantee period, it shall be corrected by the Contractor at no additional expense to the City within ten (10) calendar days of receipt of written notice from the City Representative. When the nature of the repairs as determined by the City Representative constitute an emergency (e.g. broken pressure line) the City may proceed to make repairs at the Contractor's expense. Any and all damages to existing improvement resulting either from faulty materials or workmanship, or from the necessary repairs to correct same, shall be repaired to the satisfaction of the City Representative by the Contractor, all at no additional cost to the City.

- B. Form of Guarantee: Guarantee shall be submitted on Contractors own letterhead as follows:

FORM OF:
GUARANTEE FOR SPRINKLER IRRIGATION SYSTEM

We hereby guarantee that the sprinkler irrigation system we have furnished and installed is free from defects in materials and workmanship, and the work has been completed in accordance with the drawings and specifications, ordinary wear and tear and unusual abuse, or neglect excepted. We agree to repair or replace any defects in materials or workmanship which may develop during the period of one year from date of filing of the Notice of Completion and also to repair or replace any damage resulting from the repairing or replacing of such defects at no additional cost to the City. We shall make such repairs or replacements within 10 calendar days following written notification by the City. In the event of our failure to make such repairs or replacements within the time specified after receipt of written notice from the City Representative, we authorize the City to proceed to have said repairs or replacements made at our expense and we will pay the costs and charges therefore upon demand.

PROJECT: _____
LOCATION: _____

SIGNED: _____
ADDRESS: _____

PHONE: _____

- C. After the system has been completed, the Contractor shall instruct the City Representative in the operation and maintenance of the system and shall furnish a complete set of operating instructions.
- D. Any settling of trenches which may occur during the one-year period following acceptance shall be repaired to City Representative satisfaction by the Contractor without any additional expense to the City. Repairs shall include the complete restoration of all damage to planting, paving or other improvements of any kind as a result of the work.

PART 2 - MATERIALS

2.01 GENERAL:

Materials or equipment installed or furnished that do not meet the City standards will be rejected and shall be removed from the site at no expense to the City.

2.02 PIPE:

- A. Non-pressure lines shall be Schedule 40.
- B. Pressure pipe shall be Class 200.

2.03 PLASTIC PIPE AND FITTINGS:

- A. All plastic pipe shall bear the following markings: manufacturer's name, nominal pipe size, schedule or class, type of material, pressure rating in psi, NSF seal of approval, and the date of extrusion.
- B. All plastic pipe shall be extruded of an improved PVC virgin pipe compound.
- C. Rubber gasket PVC pipe, couplings, and fittings shall conform to ASTM D 1784 Type I, Grade I, 2,000-psi design stress. Couplings, rubber gaskets, and fittings shall be as approved by the pipe manufacturer.
- D. Ring-type rubber gasket couplings shall permit a 5 degree deflection of the pipe at each coupling (2-1/2 degree each side) without exfiltration or infiltration, cracking or breaking.
- E. All fittings shall be standard weight Schedule 40 and shall be injection molded of an improved PVC fitting compound. Threaded plastic fittings shall be injection molded. All tees and ells shall be side gated.
- F. All threaded nipples shall be standard weight Schedule 80 with molded threads.
- E. All solvent cementing of plastic pipe and fittings shall be a two-step process, using primer and solvent cement applied per the manufacturer's recommendations. Cement shall be of a fluid consistency, not gel-like or ropy.

2.07 VALVES:

A. Remote Control Valves:

Valves shall be spring-loaded, self-cleaning, packless diaphragm activated, of a normally closed type.

2.08 VALVE BOXES:

- A. Valve boxes shall be fabricated from a durable, weather-resistant plastic material resistant to sunlight and chemical action of soils.
- B. The valve box cover shall be secured with a hidden latch mechanism or bolts.
- C. The cover and box shall be capable of sustaining a load of 1,500 pounds.
- D. Valve box extensions shall be by the same manufacturer as the valve box.
- E. Remote control valve boxes shall be rectangular plastic boxes with bolt-down covers marked "CONTROL VALVE"; and with the valve identification number heat branded in 2" high characters; AMETEK or approved equal.
- F. Colors of boxes shall be as called for on the plans.

2.09 ELECTRICAL:

- A. All electrical equipment shall be NEMA Type 3, waterproofed for exterior installation.
- B. All electrical work shall conform to local codes and ordinances.

2.10 WIRING:

- A. Remote control wire shall be direct-burial AWG-UF type, sized according to manufacturer's specifications, and in no case smaller than 14 gage.
- B. Connections shall be either epoxy-sealed packet-type or Penn-Tite connectors.
- C. Common wires shall be white in color. (Where two or more controllers are used, the common wires shall be white with a different color stripe for each controller.) Control wires shall be black (where two or more controllers are used, the control wires shall be a different color for each controller.) These colors shall be noted on as-built plans located on controller door.

2.11 SPRINKLERS:

Sprinklers shall be as called for on the plans.

PART 3 - EXECUTION

3.01 GENERAL:

A. Layout:

Layout irrigation systems and make minor adjustments required due to differences between site and drawings. Where piping is shown on drawings under paved areas, but running parallel and adjacent to planted areas, install the piping in the planted areas.

B. Diagrammatic Intent:

The drawings are essentially diagrammatic. The size and location of equipment and fixtures are drawn to scale where possible. Provide offsets in piping and changes in equipment locations as necessary to conform with structures and to avoid obstructions or conflicts with other work.

C. Grades:

Before starting work, carefully check all grades to determine that work may safely proceed, keeping within the specified material depths with respect to finish grade.

D. Inspections:

1. Prior to all work of this section, carefully inspect the installed work of all other trades and verify that all such work is complete to the point where this installation may properly commence.
2. Verify that irrigation system may be installed in strict accordance with all pertinent codes and regulations, the original design, the referenced standards, and the manufacturer's recommendations.

E. Discrepancies:

1. In the event of discrepancy, notify the City Representative and the Landscape Architect.
2. Do not proceed with installation in areas of discrepancy until all discrepancies have been resolved.

F. Field Measurements:

Make all necessary measurements in the field to ensure precise fit of items in accordance with the original design. Contractor shall coordinate the installation of all irrigation materials with all other work.

3.02 TRENCHING:

- #### **A. Dig trenches and support pipe continuously on bottom of ditch. Lay pipe to an even grade. Trenching excavation shall follow layout indicated on drawings to the depths below finished**

grade and as noted. Where lines occur under paved area, these dimensions shall be considered below subgrade.

- B. Provide minimum cover of 18 inches, maximum 24 inches for control wires.
- C. Provide minimum cover of 12 inches, maximum 16 inches for non-pressure lines.
- D. Provide minimum cover of 24 inches, maximum 30 inches for all pipe sleeved under paving.
- E. Where it is necessary to excavate adjacent to existing trees, the Contractor shall avoid injury to trees and tree roots. Excavation in areas where 2-inch and larger roots occur shall be done by hand. All roots 2 inches and larger in diameter shall be tunneled under and shall be heavily wrapped with wet burlap to prevent scarring or drying. Where trenching machine is run close to trees having roots smaller than 2 inches in diameter, the wall of the trench adjacent to the tree shall be hand trimmed, making a clean cut through the roots. Roots 1 inch and larger in diameter shall be painted with two coats of Tree Seal or approved equal. Trenches adjacent to trees shall be closed within 24 hours.

3.03 BACKFILLING:

- A. Initial backfill on all lines shall be of fine granular material with no foreign matter larger than 2 inch in size.
- B. Backfill shall be tamped in 4-inch layers under the pipe and uniformly on both sides for the full width of the trench and the full length of the pipe. Materials shall be sufficiently damp to permit thorough compaction, free of voids. Backfill shall be compacted to dry density equal to adjacent undisturbed soil and shall conform to adjacent grades.
- C. Flooding in lieu of tamping is not allowed without specific prior approval.
- D. Under no circumstances shall truck wheels be used to compact soil.
- E. Provide sand backfill a minimum of 6 inches over and under all piping under paved areas.

3.04 PIPING:

- A. Piping under existing pavement may be installed by jacking, boring, or hydraulic driving. No hydraulic driving is permitted under asphaltic concrete pavement.
- B. Cutting or breaking of existing pavement is not permitted.
- C. Carefully inspect all pipe and fittings before installation, removing dirt, scale, and burrs and reaming; install pipe with all markings up for visual inspection and verification.
- D. Exercise care in handling, loading, unloading, and storing plastic pipe and fittings; store plastic pipe and fittings under cover until ready to install; transport plastic pipe on a vehicle with a bed long enough to allow the pipe to lay flat, avoid undue bending and any concentrated external load.
- E. Remove all dented and damaged pipe sections.

- F. All lines shall have a minimum clearance of 6 inches from each other and 12 inches from lines of other trades.
- G. Parallel lines shall not be installed directly over one another.
- H. In solvent welding, use only the specified primer and solvent cement and make all joints in strict accordance with the manufacturer's recommended methods; allow solvent welds at least 15 minutes setup time before moving or handling and 24 hours curing time before filling.
- I. 360 degree applicators shall be used to apply primer and solvent on sizes 2 inches and larger.
- J. Centerload all plastic pipe prior to pressure testing.
- K. All threaded plastic-to-plastic connections shall be assembled using Teflon tape.
- L. For plastic-to-metal connections, work the metal connections first. Use a non-hardening pipe dope on all threaded plastic-to-metal connections, except where noted otherwise.

3.05 ASSEMBLIES:

- A. Install all assemblies specified herein according to the respective detail drawings or specifications, using best standard practice.
- B. Valves shall be installed in shrub areas whenever possible per City standards.
- C. Each valve box shall be installed on a foundation of pea gravel backfill, 3 cubic feet minimum. Valve boxes shall be installed with their tops 3/4 inch above the surface of surrounding finish grade in lawn areas.

3.06 WIRING:

- A. Wiring shall occupy the same trench and shall be installed along the same route as the pressure supply lines and shall be located below the supply lines wherever possible.
- B. Where more than one wire is placed in a trench, the wiring shall be taped together at intervals of 8' feet.
- C. All connections shall be of an approved type and shall occur in a valve box. Provide an 18-inch service loop at each connection.
- D. An expansion loop of 12 inches shall be provided at each wire connection and/or directional turn, and one of 24 inches shall be provided at each remote control valve.
- E. A continuous run of wire shall be used between a controller and each remote control valve. Under no circumstances shall splices be used without prior approval.

3.07 FLUSHING THE SYSTEM:

- A. Prior to installation of sprinkler heads, the valves shall be opened and a full head of water used to flush out the lines and risers.
- B. Sprinkler heads shall be installed after flushing the system has been completed.

3.08 SPRINKLER HEADS:

- A. Sprinkler heads shall be installed as designated on the drawings and per City standards.
- B. Spacing of heads shall not exceed maximum indicated on the drawings.

3.09 ADJUSTING THE SYSTEM:

- A. Contractor shall adjust valves, align heads, and check coverage of each system prior to coverage test.
- B. If it is determined by the City Representative that additional adjustments or nozzle changes will be required to provide proper coverage, all necessary changes or adjustments shall be made prior to any planting.
- C. The entire system shall be operating properly before any planting operations commence.

3.10 COMPLETION CLEANING:

Upon completion of the work, Contractor shall smooth all ground surfaces; remove excess materials, rubbish, debris, etc.; sweep adjacent streets, curbs, gutters, walkways, and trails; and remove construction equipment from the premises.

END OF SECTION

SECTION 02444 - CHAIN LINK FENCING

PART 1 - GENERAL

1.01 RELATED DOCUMENTS:

The provisions of *The "Greenbook" Standard Specifications for Public Works Construction* shall apply except as modified herein.

1.02 SCOPE OF WORK:

Work of this section includes that which is necessary for and incidental to completing all chain link fence work as indicated on the drawings and designated herein as follows.

- A. Fence fabric and posts
- B. Excavation for post bases
- C. Concrete anchorage for posts
- D. Gates and related hardware

1.03 REFERENCE STANDARDS:

- A. Chain Link Fence Manufacturers Institute (CLFMI) - Voluntary Standard for Chain Link Fence Installation.
- B. ASTM A120 - Hot Dip Zinc Coated (Galvanized) Welded and Seamless Steel Pipe.
- C. ASTM A123 - zinc (Hot-Galvanized Coatings on Products Fabricated from Rolled, Pressed and Forged Steel Shapes, Bars, and Strip).

1.04 SHOP DRAWINGS AND PRODUCT DATA:

- A. Submit shop drawings and product data at the preconstruction conference.
- B. Clearly indicate plan layout, grid, spacing of components, accessories, fitments, and anchorage.

PART 2 - MATERIALS

2.01 GENERAL:

All materials for chain link fencing shall conform with Section 206-6 of the latest edition of *The "Greenbook" Standard Specifications for Public Works Construction* except as modified herein.

2.02 COMPONENTS:

The base material for the manufacture of steel pipe used for posts, braces, top rails, and gate frames shall conform to the requirements of ASTM F1083, Schedule 40.

- A. Line Posts: 2.38 inch roll formed sections.
- B. Corner and Terminal Posts: 2.88 inch diameter roll formed sections.

- C. Gate Posts: 4.5 inch diameter roll formed sections.
- D. Top and Brace Rail: 1.66 inch diameter, plan end, sleeve coupled. Roll formed sections.
- E. Gate Frame: 1.90 inch diameter
- F. Caps: Cast or pressed steel or malleable iron, hot dip galvanized, sized to post dimension, set screw retained.
- G. Fittings: Sleeves, bands, clips, rail ends, tension bars, fasteners and fittings, steel galvanized.
- H. Fabric: 2 inches diamond mesh, interwoven, 9 gauge top selvage knuckle end closed, bottom selvage knuckle end closed.
- I. Bottom tension wire: 6-gauge galvanized coil spring wire.
- J. Gate hardware: Gate center rest, 2 piece drop latch, chain gate holdbrace, gate hinge, 180 degree male and female, fork latch and latch catch, and drop bolt.
- K. Fabric Ties: 11 gauge galvanized steel.
- L. Tension Bars: Galvanized high carbon steel bars not smaller than 3/16" x 3/4".
- M. Post Anchorage Concrete: Class 470-B-2000 in accordance with the Standard Specifications.

PART 3 - EXECUTION

3.01 INSTALLATION:

- A. Install all posts, all rails, and fabric to provide a rigid structure per City standards. Use manufacturer's standard fittings, fasteners, and hardware.
- B. Install posts plumb, set in concrete footings.
- C. Connect rails to posts to form continuous bracing.
- D. Fasten fabric to top rails and braces with wire ties maximum 12 inches on center.
- E. Attach fabric to end, corner, and sides with tension bars and tension bar clips.
- F. Stretch fabric between posts and rails.
- G. Install gates using fabric to match fence. Install 3 hinges per leaf, latch, catches, drop bolt, foot bolts and sockets, torsion spring retainer, retainer and locking clamp.
- H. Provide concrete center rest and drop bolt retainers at center of double gate openings.

I. Contractor to provide a set of locks for each gate conforming to City standards.

3.02 CLOSEOUT:

A. Upon completion of work of this section, the Contractor shall remove all equipment, excess material, and waste products from the site.

B. Provide a one (1) year warranty.

END OF SECTION

SECTION 02445 - TEMPORARY CHAINLINK FENCING

1.01 TEMPORARY FENCING:

Install a 6' tall (min.) temporary construction fence prior to beginning any site work, at the perimeter of active work. The fence shall be chain link (new or used), free of openings or breaks in the fabric, with fence posts at 10' O/C maximum. Fencing shall incorporate green "tennis court" windscreen material, securely fastened to top and bottom of chain link fabric, for the entire secured perimeter of the fence line. The fence shall be maintained in place throughout the construction phase period through to the end of the ninety (90) day landscape maintenance period. Install ANo Trespassing@ signs minimum 150' o.c., with wording presented in both English and Spanish. The temporary fence shall be removed prior to final inspection/project acceptance at the end of the maintenance period.

END OF SECTION

SECTION 02470 - SITE FURNISHINGS

PART 1 - GENERAL

1.01 RELATED DOCUMENTS:

The provisions of *The "Greenbook" Standard Specifications for Public Works Construction* shall also apply to this section.

1.02 SCOPE OF WORK:

The work included in this section generally consists of providing all labor, equipment and materials necessary to install all site furnishings complete as shown on the plans and as described herein.

1.03 SUBMITTALS:

- A. Contractor shall submit a written work schedule and cost breakdown for the various elements of the work at the preconstruction conference. Contractor shall also submit a complete list of materials along with manufacturers catalog data for all materials proposed for use in the work as a substitute for those specified herein.
- B. Manufacturer's Product Data: Submit six (6) copies of manufacturer's literature for each item of site furnishings.
- C. Submit suppliers certificates attesting that the materials furnished will meet specifications.

1.04 DELIVERY, STORAGE AND HANDLING:

Contractor assumes all responsibility for storage of all materials relative to this project. The City assumes no liability for losses or damages from any cause as a result of such storage.

1.05 JOB CONDITIONS - PROTECTION:

After slabs are poured and site furnishings are installed, all damage to surrounding irrigation system shall be repaired by the contractor at the contractor's expense. All trees and shrubs in and around the project site shall be protected by the contractor and, if damaged, replaced at the contractor's expense. This provision is in effect until acceptance by the City of the complete project.

1.06 LOCATION INSPECTION:

No equipment, apparatus or foundations for same shall be placed until location stakes have been inspected and accepted by the Landscape Architect.

1.07 GUARANTEE & LIABILITY INSURANCES:

- A. Manufacturer shall guarantee all materials and workmanship for a period of one (1) year exclusive of vandalism. Manufacturer will be required to provide product liability insurance coverage in the minimum amounts of \$1,000,000.00 per incident.

The manufacturer will be required to provide complete installation drawings including

specifications and a replacement parts list for all products.

- B. Contractor shall provide a written guarantee on his firm's letterhead for all materials and workmanship for a period of one (1) year exclusive of vandalism. Written guarantee shall be submitted to the City at the final inspection prior to final acceptance of the work.

PART 2 - PRODUCTS

2.01 BENCH:

Shall be precast concrete with center arm rest, model #PBBA 3684 available from Universal Precast, Inc. (408) 799-8888.

2.02 DRINKING FOUNTAIN (ADA):

Shall be model #440-SM with surface carrier available from Most Dependable Drinking Fountains, (800) 225-7473.

2.03 DRINKING FOUNTAIN (PET):

Shall be model #400-SM with surface carrier and optional pet fountain available from Most Dependable Drinking Fountains, (800) 225-7473.

2.04 PET WASTE STATION:

Shall be model #1003-L pet waste station available from Dogipot, (800) 364-7681.

2.05 TRASH RECEPTACLE:

Shall be Flare Top trash receptacle model #CBTR-FT-BK available from Belson Outdoors, (800) 323-5664.

2.06 MONUMENT SIGN:

Shall be precast concrete model #121D available from Universal Concrete, Inc. (408) 799-8888.

2.06 DOG PARK AREA & RULES SIGNS:

Shall be custom signs per construction documents available from Dogpoopsigns.com, (800) 952-1457.

2.07 AGILITY EQUIPMENT:

Shall be kits 'BARK-NVKIT' & 'BARK-ITKIT' available from Bark Park, (800) 458-8573.

2.08 SIMULATED FIRE HYDRANT:

Shall be mode TBARK-465 available from Bark Park, (800) 458-8573.

PART 3 - EXECUTION

3.01 LAYOUT:

Contractor shall stake/mark locations for all slabs and foundations and shall obtain the approval of their location from City representative prior to commencing any digging. Locations shall be adjusted to provide minimum clear distances required from all edges of slabs, trees, irrigation heads, or other obstructions.

3.02 FURNITURE INSTALLATION:

A. All site furnishings shall be installed with vandal-proof hardware or made vandal-proof (deforming or peening).

B. Block outs for "after slab installation" will not be allowed.

3.03 CLEAN-UP:

Contractor shall clean up and legally dispose of all unused materials, excess soil, and debris at regular intervals throughout the duration of the work, and as directed by the City representative.

3.04 PROTECTION OF EXISTING IMPROVEMENTS:

Contractor shall protect all existing improvements from damage.

END OF SECTION

SECTION 02480 - PLANTING

PART 1 - GENERAL

1.01 SCOPE OF WORK:

The work required is indicated on the drawings and includes, but is not necessarily limited to: soil preparation; finish grading; planting trees; guying and staking trees; maintenance; plant establishment period; guarantees; and replacement.

1.02 GUARANTEE:

- A. All trees installed under the contract shall be guaranteed against any and all poor, inadequate or inferior materials and/or workmanship for a period of one (1) year.
- B. During the guarantee period, any material found to be dead, missing, or in poor condition shall be replaced by the Contractor within ten (10) days of written notification. The City's representative shall be the sole judge as to the condition of the material.
- C. Replacement shall be made in accordance with these specifications and the plans.
- D. Material and labor involved in replacing plant material shall be provided by the Contractor at no additional cost to the City.

1.03 INSPECTIONS:

Inspections will be required. The Contractor shall contact the City's representative at least 48 hours (2 working days) in advance of an anticipated inspection. An inspection will be required at each of the steps listed below:

- A. Upon completion of fine grading, and prior to commencement of soil preparation, for acceptance of fine grading work and taking of soils samples.
- B. Inspection of completed finish grading work per this section following soil amendment work.
- C. When trees are spotted for planting, but before planting holes are excavated.
- D. When planting and all other indicated or specified work has been completed.
- E. During application of pre-emergent chemical.
- F. At start of plant establishment and maintenance period.
- G. At the end of the plant establishment period, concurrent with final acceptance of the project for maintenance by the City. This acceptance for maintenance will be confirmed in writing by the Landscape Architect.

1.04 SOILS TEST:

Contractor shall notify Landscape Architect upon completion of fine grading and prior to commencement of soil preparation work. The Contractor will obtain agronomic soils tests for all planting areas after completion of fine grading and prior to start of soil preparation work. Tests will be

performed by City approved agronomic soils testing laboratory and will include a fertility and suitability analysis with written recommendations for soil preparation, planting backfill mix, auger hole requirements, and post plant fertilization program. The soils report recommendations shall take precedence over the minimum amendment and shall be approved by the Landscape Architect PRIOR to planting in writing, and fertilizer application rates specified herein only when they exceed the specified minimums. A copy of the soils report shall be submitted to the City for approval.

1.05 SUBMITTALS:

- A. The following written certifications are required to be submitted to the Landscape Architect upon delivery of the respective materials to the job site:
 - Total Quantity of commercial fertilizers by type
 - Total Quantity of soil amendments and conditioners by type
 - Total Quantity of seed
 - Total Quantity of mulch
 - Total Quantity of iron sulphate
- B. All bagged products (seed, fertilizers, etc.) shall stay on the site in a neat and orderly manner until the final approval by the Landscape Architect.

PART 2 - MATERIALS

2.01 FERTILIZER, SOIL AMENDMENTS AND CONDITIONERS:

- A. Planting Tablets: Tightly compressed long-lasting, 12 month slow-release fertilizer tablets weighing 7 grams, and having an analysis of 12-8-8 derived from the sources listed in the following guaranteed analysis:

GUARANTEED ANALYSIS:

Total Nitrogen(N)	12%
Derived from urea formaldehyde	
7.0% water soluble nitrogen	
13.0% water insoluble nitrogen	
Available Phosphoric Acid (P ₂ O ₅)	8%
Derived from triple super phosphate	
Soluble Potash (K ₂ O)	8%
Combined Sulfur (S)	3.5%
Derived from ferrous and potassium sulphates	
Iron (expressed as elemental Fe)	2.0%
Derived from ferrous sulphate	

- B. Commercial fertilizer shall bear the manufacturer's guaranteed statement of analysis and shall meet the following minimum requirements: 14% nitrogen, 7% phosphoric acid, 7% potash with 30% humus and 6% humic acids.

C. Organic Soil Amendment:

Shall be nitrogen fortified redwood, cedar, or fir sawdust and shall contain minimum 1% available nitrogen. Material containing manure, pine, or other material will not be accepted.

D. Mulch:

Shall be nitrogen fortified redwood, cedar or fir shavings and shall contain minimum 1% available nitrogen.

E. Soil Conditioner/Fertilizer:

Shall be composted higher plant form life below the fibrous stage to support bacterial culture analysis: 5% nitrogen, 3% phosphorus, 1% potash, 50% humus, 15% humic acid, with bacteria included and 1% soil penetrant. (Gro-Power Plus) Available through Gro-Power, Inc. (800) 473-1307.

F. Soil Conditioners:

Inorganic conditioners shall be agricultural grade gypsum, soil sulfur and iron sulphate. Iron sulphate shall be ferric sulphate or ferrous sulphate in pelleted or granular form containing not less than 18.5% iron, expressed as metallic iron, and shall be registered as an agricultural mineral with the State Department of Agriculture in compliance with Article 2 "Fertilizing Materials", Section 1030 of the Agriculture Code.

2.02 PLANTS:

A. All plants shall be true to name, and one of each bundle or lot shall be tagged with the name and size of plants in accordance with the standards of practice recommended by the American Association of Nurserymen. The root condition of plants furnished in containers shall be determined by removal of earth from the roots of not less than two plants nor more than 2% of the total number of plants of each species or variety except when container-grown plants are from several different sources: in which case, the roots of not less than two plants of each species or variety from each source shall be checked by the City's Representative at his option. The selection of plants to be checked will be made by the City's Representative. All plants rendered unsuitable for planting shall be considered as samples, and replacements shall be provided at no additional cost. In case the sample plants are found to be defective, the entire lot or lots of plants represented by the defective samples will be rejected.

B. All trees supplied by Contractor shall be of the specified standard height and diameter set by the American Standard for Nursery Stock. The height of the trees shall be measured from the root crown to the last division of the terminal leader and the diameter shall be measured six (6) inches above the crown roots. The trees shall stand erect without support.

C. Bare root stock shall conform to the American Nurseryman's Association standards. Minimum caliper shall be 2" diameter and minimum height shall be 12 feet.

2.03 BACKFILL MATERIAL:

A. Topsoil shall be free from noxious weed seed and shall be of a loam characteristic, fertile and friable.

- B. Wood shavings shall be leached nitrogen fortified and shall be free of foreign matter.
- C. Soil used for backfill of planting pits shall be enriched using the following blend per cubic yard (agronomic soil test recommendations to be reviewed prior to soil mixing) and have written approval by Landscape Architect before planting.

- 60% site soil or approved import
- 40% wood shavings
- 17 lbs. soil condition/fertilizer (Gro-Power Plus)
- 1 lb. iron sulphate

All plant pits shall be backfilled with backfill mix as specified above.

- D. All soil backfill shall be bulk mixed, not individually mixed at each plant pit.

2.04 STAKES AND TIES:

- A. Tree stakes shall be 3" dia. x 10 foot long straight- grained copper naphthanate treated lodgepole pine. Stakes shall be free from knots, checks, splits, or disfigurements.
- B. Tree ties shall be "Twist Brace@ supplied by V.I.T. Co., Escondido, California, (760) 480-6702. For 15 gallon - 24" box trees, Model TB24; for 36" box trees, Model TB36.

2.05 HERBICIDE ERADICATION:

Gro-Safe as manufactured by Target Chemical Co. (714) 821-9020; or approved equal.

PART 3 - EXECUTION

3.01 LANDSCAPE GRADING:

The Contractor shall complete preliminary grading filling as needed or removing surplus dirt, removing rocks and debris over 1 inch in diameter within the top 2" of soil in flat and slope areas, and removing rocks over 2" in diameter within the top 6" of soil in areas with slopes less than 3:1. Bring all areas to be landscaped to finish grade. All areas shall slope to drain. Flow lines shall be established to existing road curbs and/or sidewalks as shown on the plans and as directed.

3.02 WEED CONTROL MEASURES:

- A. Upon completion of all fine grading work and prior to soil preparation, perform weed control measures as follows:
 - 1. Irrigate all areas designated to be planted for a minimum of 10 minutes per setting, two settings per day for seven days to germinate all weed seed possible.
 - 2. Apply a contact weed killer and allow sufficient time to obtain complete kill of all weeds germinated.
 - 3. Repeat step one above.

4. Repeat step two above.

3.03 SOIL PREPARATION:

- A. All fine grading and mounding and all weed control measures shall be completed prior to soil preparation.
- B. This work shall not commence until the agronomic soils test has been completed. Should 30 calendar days elapse between completion of soil preparation and commencement of planting, all areas shall be prepared again.
- C. In planting areas with gradients less than 3:1, a layer of soil amendments shall be spread and rototilled into the soil to a minimum depth of 4 inches, or as recommended by the soils report, so that the soils shall be loose, friable, and free from all rocks, sticks, and other objects undesirable to planting.
- D. The following soil amendments shall be added per 1,000 square feet to all planting areas with gradients less than 3:1 (agronomic soil test recommendations shall take precedence where these minimum amounts are exceeded) and need written approval by the Landscape Architect before planting.
 1. 3 cubic yards organic amendment.
 2. 200 pounds soil conditioner/fertilizer (Gro-Power Plus)
 3. 25 pounds gypsum.

All landscape areas shall be finish graded to "dress out", maintain, and/or reestablish grades and flow lines as approved prior to amending the soil. Finish grades will be inspected upon completion. Contractor shall not proceed with planting work until finish grades have been inspected and accepted by the Landscape Architect.

3.04 FINISH GRADING:

After completion of all soil preparation work the Contractor shall finish grade all planting areas filling as needed or removing surplus dirt, removing rocks and debris over 1 inch in diameter, and floating to a smooth uniform grade. All areas shall slope to drain. Flow lines shall be established to existing road curbs and/or a sidewalk as shown on the plans and as directed.

3.05 PLANTING:

- A. Trees: Plant holes shall be dug to size as indicated in the drawings. Before trees are set in the holes, a water test should be made as follows:

All plant holes shall be filled to the brim with water and allowed to drain before any planting is done. If water does not drain out of hole within 24 hours, this fact must be brought to the attention of the Landscape Architect so that corrections can be made. Correctional work shall be considered as an extra, at additional expense.

- B. Soil surrounding planting pit shall be in a friable condition and moist to a depth of 8".
- C. Backfill using specified soil mix to within 8" of finish grade. At this depth, place the plant fertilizer tablets Gro-Power planting tablets, 12-8-8, 7 grams each or equal. A minimum of 3 tablets for 1 gallon; 8 tablets for 5 gallons; 15 tablets for 15 gallons, and 22 tablets for a 24" box. Complete backfilling to finish grade.
- D. Trees shall be planted at such a depth that the crown roots bear the same relative position to finish grade as they did to the soils where they were grown. Backfill after planting shall be compacted carefully into place without injuring the roots of the tree or breaking up the ball of earth surrounding the roots.

3.06 TREE STAKING:

Stake trees as per planting details. No metal wire shall circle any part of any tree.

3.07 WATERING:

- A. It shall be the Contractor's responsibility to maintain a balanced watering program to ensure proper growth until final acceptance of the work.
- B. Immediately after planting, apply water to each tree. Apply water in a moderate stream in the planting hole until the material about the roots is completely saturated from the bottom of the hole to the top of the ground.
- C. Apply water in sufficient quantities and as often as seasonal conditions require to keep the planted areas moist at all times, well below the root system of plants.
- D. Irrigation:
 - 1. Contractor shall properly and completely maintain the irrigation system. A balanced water program shall be maintained to ensure proper growth until final acceptance of the work. Plants which cannot be watered efficiently with the irrigation system shall be watered by means of a hose.
 - 2. All controllers are to have each station individually adjusted on a weekly basis. System shall be set considering the application rate each area is capable of receiving. The system shall operate on short intervals, with the cycle repeating at a later time to reduce runoff.

3.08 MAINTENANCE:

- A. All areas landscaped by Contractor under this contract shall be maintained by him for a minimum plant establishment period of not less than ninety (90) days from the date of written acceptance for start of the plant establishment period.
- B. Contractor shall maintain existing planted areas which are within the work limits of the contract as shown on the plans. This maintenance shall continue for the duration of the construction period. The contractor shall provide and allow access by City maintenance people into or through work limit areas for the purpose of normal maintenance of existing

park areas remaining outside of the work limit areas.

3.09 START OF PLANT ESTABLISHMENT:

A. Criteria for start of plant establishment period:

1. The plant establishment period shall not start until all elements of the project that impact the landscape are completed in accordance with the contract documents. Projects will not be segmented into phases.
2. Permanent Power to remote controllers shall be established.
3. Written acceptance of the City must be obtained to the start of the plant establishment period.
4. If the project maintenance fails to continuously meet standards required, the plant establishment period "day count" will be suspended and will not recommence until Contractor has corrected all deficiencies.

3.10 MAINTENANCE TASKS:

A. General:

During the contract period provide all watering, weeding, fertilizing and cultivation, and spraying necessary to keep the trees in a healthy growing condition and to keep the planted areas neat and attractive. All trees planted under the contract shall be pinched and pruned as necessary to encourage new growth and to eliminate sucker growth. Old wilted flowers and dead foliage shall be immediately pinched or cut off. Do no tree pruning without the written approval of the Landscape Architect.

B. Iron Chlorosis:

After planting and during the plant establishment period in the event that trees exhibit iron chlorosis symptoms, apply FE 138 Geigy or equivalent at manufacturer's recommended rates.

C. Replacement Plantings:

During the plant establishment period, should the appearance of any plant indicate weakness, that plant shall be replaced immediately with a new, healthy plant. At the end of the plant establishment period, all plant materials shall be in a healthy, growing condition and spaced as indicated on the plans.

D. Planting Establishment:

Any planting areas that do not show a prompt establishment of plant material shall be replanted at 10-day intervals until the plant material is established. If a good rate of growth has not been demonstrated within 30 days of first planting, the Contractor shall be responsible to determine the appropriate horticultural practices necessary to obtain good growth. The Contractor shall obtain agronomic soils testing of all areas not showing good growth and shall provide copies of the test results to the City to verify the appropriateness of all maintenance work performed. If additional soil amendments are needed, up to a maximum 25% beyond

the amount specified, such amendments shall be provided by the Contractor at no additional cost to the City.

E. Grading and Drainage:

During the plant establishment period all flow lines shall be maintained to allow for free flow of surface water. Displaced material which interferes with drainage shall be removed and placed as directed. Low spots and pockets shall be graded to drain properly. Jute netting shall be installed at flow lines and other locations where erosion is evident, when directed by the inspector.

1. Damage to planting areas shall be repaired immediately and throughout the plant establishment period. Depressions caused by vehicles, bicycles, or foot traffic shall be filled and leveled. Replant damaged areas.
2. All paved areas shall be washed and maintained in a neat and clean condition at all times.
3. Debris and trash shall be removed from the site weekly at a minimum.
4. All subsurface drains shall be periodically flushed with clear water to avoid build up of silt and debris. Keep all drain inlets clear of leaves, trash, and other debris.

F. Disease and Pest Control:

Throughout the plant establishment period, all plants shall be maintained in a disease and pest free condition. A licensed pest control operator shall be retained by the Contractor to recommend and apply all pesticides, herbicides, and fungicides. Exterminate gophers, moles, and all other rodents, and repair damage.

G. Trash:

Debris and trash shall be removed from the site weekly at a minimum.

3.11 END OF PLANT ESTABLISHMENT PERIOD:

- (1) When the Contractor believes he has completed the plant establishment period and the entire project is ready for final acceptance, he shall request inspection of the project. The Landscape Architect will inspect the project for final acceptance. Deficiencies noted during inspection shall extend the plant establishment period until all are corrected.
- (2) All planting areas shall show a good rate of growth and shall be well established "filled in" plantings free of voids. Bare areas will be unacceptable. Contractor shall provide sod or planting from flats as necessary to fill in all bare areas. Such sod or plantings shall be planted a minimum of 10 days prior to the end of the plant establishment period and shall have roots "knit-in" to the native soil.
- (3) Final acceptance shall occur only upon written acceptance of the project for maintenance by the Landscape Architect.

3.18 CLEAN UP:

Upon completion of the work, the Contractor shall smooth all ground surfaces; remove excess materials, rubbish, debris, etc.; sweep adjacent streets, curbs, gutters, walkways, and trails; and remove construction equipment from the premises.

END OF SECTION

SECTION 03010 - CONCRETE

PART 1 - GENERAL

1.01 QUALITY ASSURANCE:

- A. Codes and Standards: Comply with the provisions of the following codes, specifications and standards, except where more stringent requirements are shown or specified:
 - 1. ACI 301 "Specifications for Structural Concrete for Building."
 - 2. ACI 318 "Building Code Requirements for Reinforced Concrete."
 - 3. ACI 347 "Recommended Practice for Concrete Formwork."
 - 4. ACI 304 "Recommended Practice for Measuring, Mixing, Transporting and Placing Concrete."
 - 5. Concrete Reinforcing Steel Institute, "Manual of Standard Practice."
 - 6. California Building Code (CBC), 2013 Edition.
- B. Testing: Owner's testing laboratory will perform sampling and testing during concrete placement, which may include the following, as directed by the Landscape Architect. Comply with LABC Section 91.2604.3.
 - 1. Sampling: ASTM C 172.
 - 2. Slump: ASTM C 173, one test for each load at point of discharge.
 - 3. Air Content: ASTM C 173, one for each set of compressive strength specimens.
 - 4. Compressive Strength: ASTM C 39, one set for each 50 cu. yds. of each grade of structural concrete; and at least one test for each day's concreting for each grade of concrete used, two specimens tested at 28 days.

1.02 SUBMITTALS:

- A. Comply with pertinent provisions of Section 01300.
- B. For all concrete, a signed copy of batch plant's certificate stating the quantity of each material, amount of water, admixtures, departure time and date shall accompany each load of materials or concrete.
- C. Submit test results as required by the City.
- D. Product Data: Submit manufacturer's product data with installation instructions for proprietary materials including reinforcement and forming accessories, admixture, joint materials, hardeners, curing materials and others as requested by the Landscape Architect.

- E. Laboratory Reports: Submit laboratory test or evaluation reports for concrete materials and mix designs as required by the City.

PART 2 - PRODUCTS

2.01 FORM MATERIALS:

- A. Unless otherwise indicated, construct formwork for exposed concrete surfaces with 2x lumber or other acceptable panel-type materials, to provide continuous, straight, smooth, exposed surfaces. Furnish in largest practicable sizes to minimize number of joints and to conform to joint system shown on drawings. Provide form materials with sufficient thickness to withstand pressure of newly-placed concrete without bow or deflection.

2.02 CONCRETE MATERIALS:

- A. Portland Cement: ASTM C 150, type I or type II.
- B. Aggregates: ASTM C 33, except local aggregates of proven durability may be used when acceptable to the Landscape Architect. Provide aggregates from a single source for exposed concrete.
- C. Water: Potable.

2.03 CONCRETE ADMIXTURES:

- A. General: Provide admixtures produced by established reputable manufacturers and use in compliance with the manufacturer's printed directions. Do not use admixtures which have not been incorporated and tested in accepted mixes, unless otherwise authorized in writing by the Landscape Architect.
- B. The following admixtures may be used with written approval of the Landscape Architect. Conform to manufacturer's recommendations for use.
 - 1. Water Reducing: ASTM C 494. Shall provide a minimum of 5% water reduction, 10% increase of 28 day compressive strength, drying shrinkage at 21 days shall be less than concrete without admixture.
 - 2. Acceleration or Retarding: ASTM C 494.
- C. Waterproofing Admixture: SIKA CHEMICAL CORPORATION "Sika Red Label" (Sikamix 198).
- D. Calcium chloride not permitted.

2.04 JOINT MATERIALS:

- A. Keyed Metal Joint: BURKE CONCRETE ACCESSORIES "Keyed Kold" 24 gauge galvanized steel joint form with steel "Keyed Kold" stakes.
- B. Fiber Joint Filler: ASTM D 1751 non-extruding premolded bituminous impregnated fiberboard units. Plain or punched for dowels as required.

- C. Plastic Joint Insert: "Quickjoint" T-shaped 1/16" plastic strip, 1 inch minimum depth as distributed by J.A. CRAWFORD CO., phone (213) 698-0901.

2.05 VAPOR BARRIER:

- A. Provide vapor barrier cover over prepared base material where shown on drawings. Use only materials which are resistant to decay when tested in accordance with ASTM D 154, as follows:
 - 1. Provide polyethylene sheet not less than 10 mils thick.

2.06 FINISH MATERIALS:

- A. Sealer: A.C. HORN "Horntraz."

2.07 CURING MATERIALS:

- A. Liquid Curing Compound: ASTM C 309, type 1 non-staining, approved standard product resin type.
 - 1. Gray Cement: Free of wax or oil, compatible with subsequently applied finishes or coverings, delivered in unopened labeled containers.
- B. Concrete Curing Paper: ASTM C 171, non-staining reinforced type.

2.08 PATCHING MATERIAL:

- A. Bonding Agent: LARSON PRODUCTS "Weldcrete," W.R. GRACE "Daraweld" or SONNEBORN-CONTECH "Soncrete."
- B. Patching Mortar: Latex modified Portland Cement mortar. Provide CUSTOM BUILDING PRODUCTS "Fix-a-crete."

2.09 PROPORTIONING:

- A. Proportioning shall be by weight of loose, dry material, 94 pounds of cement shall be considered 1 cubic foot. Fine aggregate volume shall be at least 35% of the sum of the separate fine and coarse aggregate volumes.

Weighing equipment shall be accurate to within 1 pound and be adjustable for varying aggregate moisture content. A beam auxiliary shall register any part of the last 100 pounds of each aggregate. The aggregate hopper shall have a volume adjustment.

- B. Accurately control the proportions, water content, and air content.
- C. Waterproofing Admixture: Add to all concrete used for exposed roof slabs, slabs on grade and walls against grade. Add in accordance with manufacturer's instructions.
- D. Admixture (other than waterproofing and integral color): If admixture is used, conform to type specified. Quantity per sack of cement and method of using admixture shall be

in accordance with recommendations of manufacturer and laboratory furnishing mix design.

- E. Non-shrink Grout: Pre-proportioned, or job mixed. For job-mix: one part, by weight, metallic aggregate mix; one part Portland cement; one part fine aggregate; and enough water for flowable consistency.
- F. Cement Grout: One part by volume Portland cement and 2 1/2 parts fine aggregate. Mix dry. Add just enough water to make mixture flow under its own weight.
- G. Dry Pack: One part by volume Portland cement and 2 1/2 parts fine aggregate, mixed dry. Add just enough water to dampen mix to a cohesive packing or tamping consistency.
- H. Patching Mortar: Mix liquid. Combine dry mix with liquid and add water in proportions recommended by manufacturer.

2.10 MIX DESIGN:

- A. Prepare design mixes for each type and strength of concrete indicated on plans.
 - 1. Proportions: For each material including admixtures and water, state water-cement ratio and maximum allowable water content, using not less than the minimum cement content required in paragraphs "proportioning."
 - 2. Materials: Manufacturer's name, designation and source of each material.
 - 3. Aggregate: Conform to LABC Section 91.2603.3.
 - 4. Modified Mix: Same as other concrete types except remove 50% of the coarse aggregate.

2.11 CONCRETE TYPES:

- A. Refer to structural drawings for specific uses and locations.
- B. Specified strengths measured at 28 days.
 - 1. Standard Weight Concrete: 2500 psi. minimum unless otherwise specified.

2.12 MIXING CONCRETE:

- A. Ready-Mixed Concrete: Concrete shall be supplied by an established commercial ready-mix plant conforming to ASTM C 94.
 - 1. Truck Mixers: Minimum 2 cu. yd. capacity, equipped with accurate revolution counter. Operate at rated speed. Discontinue use of mixers producing unsatisfactory concrete or showing more than 10% difference in sand-cement or water-cement ratios in samples taken from front, center and back of mixer.

2. Mixing Time: Total at least 15 minutes, with at least 5 minutes immediately after addition of water, and at least 10 minutes just before discharging.
 3. Mixing Water: Withhold 2 1/2 gallons per cubic yard from predetermined water content. All or part thereof may be added at site, as directed.
- B. Re-tempered Concrete: Concrete not placed within 90 minutes after water is introduced into mix or which has stood for 30 minutes after leaving mixer shall not be used.

PART 3 - EXECUTION

3.01 FORMS:

- A. Design, erect, support, brace and maintain formwork to support vertical and lateral loads that might be applied until such loads can be supported by concrete structure. Construct formwork so concrete members and structures are of correct size, shape, alignment, elevation and position. Comply with ACI 347.
- B. Design and fabricate formwork to be readily removable without impact, shock or damage to cast-in-place concrete surfaces and adjacent materials.
- C. Provide temporary opening where interior area of formwork is inaccessible for cleanout, for inspection before concrete placement and for placement of concrete.
- D. Chamfer exposed corners and edges as indicated, using wood, metal, PVC or rubber chamfer strips fabricated to produce uniform smooth lines and tight edge joints.
- E. Form Ties: Factory fabricated, adjustable length, removable or snap-off metal form ties, designed to prevent form deflection, and to prevent spalling concrete surfaces upon removal.
- F. Provide openings in formwork to accommodate work of other trades. Accurately place and securely support items build into forms.

3.02 VAPOR BARRIER:

- A. Place interior slabs on grade over vapor barrier consisting of 2 inch bed of washed natural sand over vapor barrier sheet. Turn up edges of vapor barrier 2 inches. Lap edges 6". Tape and seal all edge laps and penetrations. Roll sub-grade smooth prior to placing vapor barrier.
 1. Omit stakes at metal joints occurring over vapor barrier. Use screed pads to hold screed posts. Do not pierce vapor barrier.
 2. Do not disturb or damage vapor barrier while placing metal formed joints and concrete reinforcing. If damage does occur, repair areas before placing concrete. Use vapor barrier material, lapped over damaged areas minimum 6" in all directions and seal.

3.05 JOINTS:

- A. Provide construction, isolation, and control joints as indicated or required. Locate construction joints so as to not impair the strength and appearance of the structure. Place isolation and control joints in a slabs-on-ground to stabilize differential settlement and random cracking.
- B. Metal Formed Joint: "Key-Kold" type metal joint form. Set top of stakes 3/8" below slab surface elevation, spaced at 2'-0" o.c.. When concrete is not poured continuously over both sides of joint, the knockout anchors shall be bent at 45 degree angle into the pour. Finish the concrete to the top of the joint and burn in with hand trowel.

3.06 INSTALLATION OF EMBEDDED ITEMS:

- A. Set and build into the work anchorage devices and other embedded items required for other work that is attached to, or supported by cast-in-place concrete. Use setting diagrams, templates and instruction provided by others for locating and setting.

3.07 CONCRETE PLACEMENT:

- A. Pre-placement Inspection: Before placing concrete, inspect and complete formwork installation, reinforcing steel, and items to be embedded or cast-in. Notify other crafts to permit installation of their work; cooperate with other trades in setting such work. Moisten wood forms immediately before placing concrete where form coatings are not used.
- B. Coordinate the installation of joint materials and moisture barriers with placement of forms and reinforcing steel.
- C. Comply with ACI 304, placing concrete in a continuous operation within planned joints or sections. Do not begin placement until work of other trades affecting concrete is completed.
- D. Consolidate placed concrete using mechanical vibrating equipment with hand rodding and tamping, so that concrete is worked around reinforcement and other embedded items and into all part of forms.
- E. Maintain reinforcing in proper position during concrete placement operations.
- F. Tolerances: Variations in finish surfaces shall not exceed 1/8 inch in any direction along a 10 foot straightedge.
- G. Protect concrete from physical damage or reduced strength due to weather extremes during mixing, placement and curing.
 - 1. In cold weather comply with ACI 306.
 - 2. In hot weather comply with ACI 305.

3.08 FINISH OF FORMED SURFACES:

- A. Rough Form Finish: For formed concrete surfaces not exposed-to-view in the finish work, unless otherwise indicated. This is the concrete surface having texture imparted by form facing material used, with tie holes and defective areas repaired and patched and fins and other projections exceeding 1/4" in height rubbed down or chipped off.
- B. Smooth Form Finish: For formed concrete surfaces exposed-to-view, or that are to be covered with a coating material applied directly to concrete, or a covering material applied directly to concrete, such as waterproofing, damp-proofing, painting or other similar system. This is as-cast concrete surface obtained with selected form facing material, arranged orderly and symmetrically with a minimum of seams. Repair and patch defective areas with fins or other projections completely removed and smoothed.

3.09 SLAB FINISH:

- A. Non-Slip Broom Finish: Apply non-slip broom finish to exterior concrete paving.
 - 1. Immediately after trowel finishing, slightly roughen concrete surface by brooming with hair bristle broom perpendicular to main traffic route. Coordinate required final finish with the Landscape Architect before application.
- B. Sealer: Apply to scheduled areas in accordance with manufacturer's printed instructions.

3.10 CONCRETE CURING:

- A. General: Protect freshly placed concrete from premature drying and excessive cold or hot temperatures.
 - 1. Start initial curing as soon as free water has disappeared from concrete surface after placing and finishing. Weather permitting, keep continuously moist for not less than 7 days.
 - 2. Begin final curing procedures immediately following initial curing and before concrete has dried. Continue final curing for at least 7 days in accordance with ACI 301 procedures. Avoid rapid drying at end of final curing period.
- B. Curing Methods: Perform curing of concrete by moist curing, by moisture retaining cover curing, by curing compound, and by combination thereof, as herein specified.
- C. Do not use membrane curing compounds on surfaces which are to be covered with coating material applied directly to concrete, liquid floor hardener, waterproofing, damp-proofing, membrane roofing, flooring, painting, and other coatings and finish materials, unless otherwise acceptable to the Landscape Architect.
- D. Curing Formed Surfaces: Cure formed concrete surfaces, including undersides of beams, supported slabs and other similar surface by moist curing with forms in place for full curing period or until forms are removed. If forms are removed, continue curing by methods specified above, as applicable.
- E. Curing Unformed Surfaces: Cure unformed surfaces, such as slabs, floor topping, and

other flat surfaces by application of appropriate curing compound.

3.11 REMOVAL OF FORMS:

- A. Time: Remove forms after concrete has developed sufficient strength to sustain its own weight and superimposed loads, but not before the time listed below:
 - 1. Slabs: 1 day.

3.12 RE-USE OF FORMS:

- A. Clean and repair surfaces of forms to be re-used in the work. Split, frayed, delaminated or otherwise damaged form facing material will not be acceptable. Apply new form coating compound material to concrete contact surfaces as specified for new formwork.
- B. When forms are extended for successive concrete placement, thoroughly clean surfaces, remove fins and laitance, and tighten forms to close all joints. Align and secure joints to avoid offsets. Do not use "patched" forms for exposed concrete surfaces, except as acceptable to the Landscape Architect.

3.13 MISCELLANEOUS CONCRETE ITEMS:

- A. Equipment Bases: Form concrete bases for all mechanical and electrical equipment indicated on the drawings, including architectural, structural, mechanical, electrical, and plumbing drawings, in accordance with approved shop details furnished by the various trades. Corners shall be bullnosed and bases shall be coved.
 - 1. Set anchor bolts for machines and equipment to template at correct elevations, complying with certified diagrams or templates of manufacturer furnishing machines and equipment.
- B. Pits, Trenches, Curbs: Form and pour pits for valves, trenches, curbs, and miscellaneous concrete items. Steel trowel surfaces hard, dense and smooth with corners, intersections, and terminations rounded. Where structural details for minor structures listed above do not specify otherwise, walls, floors and covers shall be 6" thick, reinforced with #3 bars, 6" o.c. both ways at center of members.

3.14 CONCRETE SURFACE REPAIRS:

- A. Patching Defective Areas: Repair and patch defective areas with cement mortar immediately after removal of forms, when acceptable to the City representative.
- B. Remove and replace concrete having defective surfaces if defects cannot be repaired to satisfaction of the City representative.
- C. Do not leave exposed steel ties, clamps, in concrete. Solid pack holes resulting from form construction after flushing them with water. Fill tie wire, nail, bolt, nut, separator and core sample holes, which will be exposed within 24 hours after forms are stripped.
 - 1. Cut out honeycomb, rock pockets, voids over 1/4" in any dimension, and holes left by tie rods and bolts, down to solid concrete but, in no case to a depth of less

than 1". Make edges of cuts perpendicular to the concrete surface. Thoroughly clean, dampen with water and brush-coat the area to be patched with specified bonding agent. Place patching mortar after bonding compound has dried.

2. Match surrounding architectural concrete surfaces in color and texture. Make trial patch to determine color match.

3.15 FIELD QUALITY CONTROL:

- A. Slump Tests: Measure concrete consistency by the "Standard Method of Test for Slump of Portland Cement Concrete," ASTM Designation C 143. Make this test at point of discharge twice each day or partial day's run. A complete and accurate record of these tests shall be kept by the inspector. Maximum slump shall be as follows:
 1. Walls 4" to 5".
 2. Floor slab on grade, 3" to 4".
- B. Cylinder Samples: Make concrete test cylinder samples in accordance with ASTM C 31.

3.16 DEFECTIVE CONCRETE:

- A. Mix Proportions: If ultimate compressive strength of test cylinders fall below minimum assumed in design, proportions of concrete mixes for remaining portion of structure shall be adjusted as required to produce concrete of design strength.
- B. Test Cores: Should the required test cylinders fail to show design compressive strength, test cores shall be taken at locations designated by the Landscape Architect. Cores shall be tested complying with LABC Section 91.2604.3.5.1. If results show compressive strength to be less than design stress, concrete shall be deemed defective and shall be replaced in a manner acceptable to the City representative, and the Building Department. Cost of cores, tests, and patching shall be paid by Contractor. Coring holes shall be dry-packed.
- C. Concrete work not formed as indicated, not true to intended alignment, not plumb, level, or true to intended grades, with embedded sawdust or debris, and not fully conforming to the provisions of these specifications shall be deemed defective and shall be removed from the job site as directed by the City representative and shall be replaced with concrete complying with specification requirements.

END OF SECTION

SECTION 03310 - FOOTINGS AND FOUNDATIONS

PART 1 - GENERAL

1.01 RELATED DOCUMENTS:

The provisions of *The "Greenbook" Standard Specifications for Public Works Construction* shall apply except as modified herein.

1.02 SCOPE OF WORK:

Work included: Provide all footings and foundations, complete in place, as indicated on the drawings, specified herein, and needed for a complete and proper installation.

1.03 QUALITY ASSURANCE:

Qualifications of Installers:

Throughout the progress of installation of the work of this Section, provide at least one person who shall be thoroughly familiar with the specified requirements, completely trained and experienced in the necessary skills, and who shall be present at the site and shall direct all work performed under this Section.

Use adequate number of skilled workers to ensure installation in strict accordance with the approved design.

Details provided on plans with notes. If notes conflict with book specification, the more stringent shall apply.

PART 2 - MATERIALS

2.01 GENERAL:

All materials shall conform to Section 201 of the latest edition of *The "Greenbook" Standard Specifications for Public Works Construction*.

- A. Portland Cement: Section 201-1.2.1, Type I or II, low alkali. Only one brand of cement shall be used.
- B. Aggregates: Conform to Section 201-1.2.2.
- C. Water shall be clean and free from deleterious materials.
- D. Form lumber shall be uniform construction grade or better.
- E. Provide reinforcement steel as indicated on the drawings and in conformance with the requirements of the uniform building code latest edition.

PART 3 - EXECUTION

3.01 GENERAL:

All materials shall conform to Section 302.6 of the latest edition of *The "Greenbook" Standard Specifications for Public Works Construction* except as modified herein.

3.02 CONCRETE MIX:

- A. The Contractor shall supply and pay all costs for concrete mix designs.
- B. In no case shall concrete contain less than 5 sacks of cement per cubic yard, and a maximum of 7 gallons of water per sack of cement.
- C. Concrete mixes shall be proportioned by the using of 1-inch maximum size aggregate.
- D. Concrete shall develop an ultimate compressive strength at 28 days of 3000 P.S.I. Special Inspector shall be provided at the Contractor's expense.
- E. The maximum slump for slab on grade shall be 4".

3.03 TESTS AND INSPECTION:

- A. The quality and quantity of materials used in the concrete shall be controlled at the batch plant by a Weighmaster.
- B. Contractor shall deliver two copies of each load ticket to the City.

3.04 FORMWORK:

- A. Form shall be substantial, unyielding, true to line and grade, and shall conform to the dimensions indicated on the drawings.
- B. Edge of footing shall not cross property line or right of way line.

3.05 TRANSPORTATION AND PLACING CONCRETE:

Responsibility for proper placing, compacting and finishing rests with the Contractor. Finished work showing voids and separation of aggregates will not be accepted.

3.06 CURING CONCRETE:

All concrete surfaces shall be kept continuously wet for a period of not less than 36 hours by ponding, soaking or spraying. Following this 36 hour period, the concrete shall be protected from loss of moisture by an approved liquid curing compound.

END OF SECTION

SECTION 03380 - CONCRETE CURING

PART 1 B GENERAL

1.01 RELATED DOCUMENTS:

The provisions of *The "Greenbook" Standard Specifications for Public Works Construction* shall apply except as modified herein.

1.02 SCOPE OF WORK:

Furnish materials, labor, transportation, services, and equipment necessary to install all Concrete Curing related to the park as indicated on the Drawings complete as shown and as specified herein.

Related Work:

Concrete	Section 03010
Footings & Foundations	Section 03310

1.03 REFERENCES:

Comply with the applicable reference specifications as specified in the Special Provisions and in accordance with applicable laws, codes and regulations required by the City of Pomona, CA. Comply with the current provisions of the following Codes and Standards:

ASTM - American Society for Testing and Materials:

ASTM C94 B Ready-Mixed Concrete.

ASTM C150 B Portland Cement.

ASTM C271 B Sheet Materials for Curing Concrete.

ASTM C309 B Liquid Membrane-Forming Compounds for Curing Concrete.

ACI B American Concrete Institute:

ACI 301 B Specifications for Structural Concrete for Buildings.

ACI 305 B Recommended Practice for Hot Weather Concreting.

ACI 306 B Recommended Practice for Cold Weather Concreting.

ACI 318 B Building Code Requirements for Reinforced Concrete.

CBC B 2013 Edition of the California Building Code

1.04 SUBMITTALS:

In accordance with Contract Documents, General and Technical Provisions.

Submit product data and manufacturer's instructions for:

1. Curing compound.
2. Proprietary cleaning agents.
3. Plastic film for curing.
4. Surface retarders.

1.05 DELIVERY, STORAGE, AND HANDLING:

Store materials in dry and protected locations and protect from damage.

1.06 SITE CONDITIONS:

Environmental Requirements: Protect concrete against extreme cold and heat, frost, rapid drying, and damage by rain.

PART 2 - PRODUCTS

2.01 MATERIALS:

Curing Compound: ASTM C 309, non-staining, all resin type, white-pigmented, compatible with color admixture.

Acceptable Product: Burke Spartan-Cote Cure or equal. Curing Compound Application Rate: 350 sq. ft./U.S. Gallon (12.5m sq./L)

PART 3 - EXECUTION

3.01 CURING:

Protect concrete surfaces against rapid drying. Keep sealed with cure agent for necessary amount of time to reach concrete strength and inhibit moisture loss after placing per manufacturer=s recommendation.

Apply to exposed surface of concrete as soon as manufacturer recommends with an airless sprayer.

Apply to sides of concrete paving upon removal of form boards.

Meet requirements of manufacturer=s current printed application instructions.

Uniformly apply 2 coats and apply the second coat at right angle to first coat.

Apply compound to form a continuous, uniform, coherent film that will not check, crack, or peel.

Do not apply to concrete that is still bleeding, or has a visible water sheen on the surface.

Protect paving surfaces from foot traffic with scuff-proof paper.

Immediately re-coat damaged areas of curing compound.

Protect surface from water, adjacent concrete work and debris.

3.02 CLEANUP:

Contractor to remove all cure agent from concrete surface with power washing equipment and soft brush not causing abrasion to finish work surface prior to final inspection. No Cure Agent shall be

present on any surfaces for final inspection acceptance. Remove debris and trash resulting from specified work.

END OF SECTION

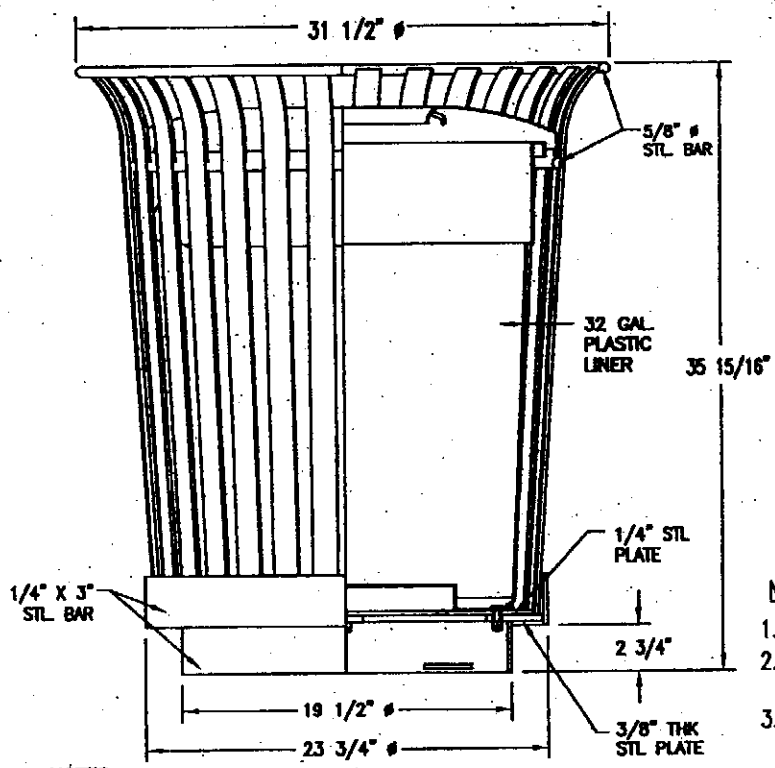
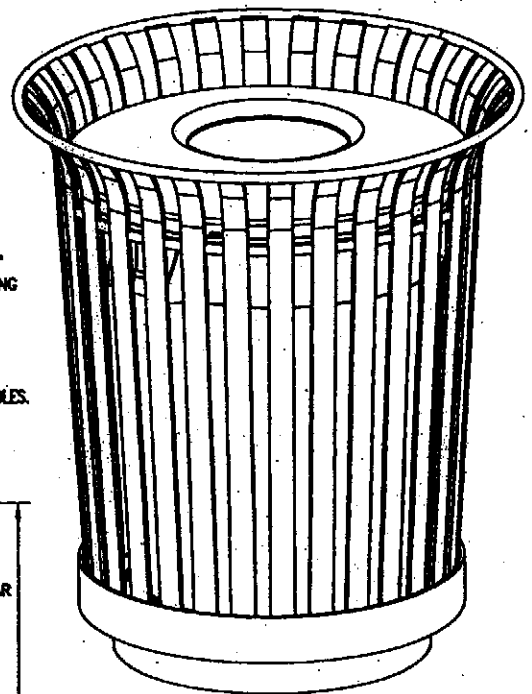
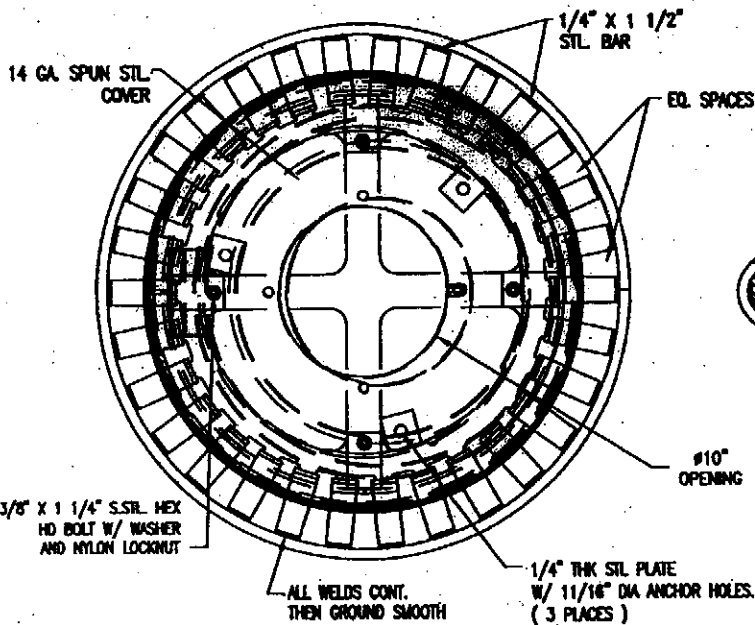

NOTE:
 1.) RECEPTACLE SHIPPED FULLY ASSEMBLED.
 2.) COVER ATTACHED W/ 1/8\"/>

- NOTES:**
- 1.) ALL STL. MEMBERS COATED W/ ZINC RICH EPOXY THEN FINISHED W/ POLYESTER POWDER COATING.
 - 2.) 1/2\"/>

CITY OF POMONA PUBLIC WORKS DEPARTMENT			
RECEPTACLE			
	DRAWN BY: M.L.	CHECKED BY: V.L.	
	APPROVED		STANDARD
	CITY ENGINEER		
REVISIONS	DATE	INITIAL	